

M7892 A21

Security Target Lite

Version 1.2, 2011-12-13

Author: Hans-Ulrich Buchmüller

Public



INTEGRITY GUARD



SOLID FLASH™

Edition 2011-12-13

Published by
Infineon Technologies AG
81726 Munich, Germany

© 2012 Infineon Technologies AG
All Rights Reserved.

Legal Disclaimer

The information given in this document shall in no event be regarded as a guarantee of conditions or characteristics. With respect to any examples or hints given herein, any typical values stated herein and/or any information regarding the application of the device, Infineon Technologies hereby disclaims any and all warranties and liabilities of any kind, including without limitation, warranties of non-infringement of intellectual property rights of any third party.

Information

For further information on technology, delivery terms and conditions and prices, please contact the nearest Infineon Technologies Office (www.infineon.com).

Warnings

Due to technical requirements, components may contain dangerous substances. For information on the types in question, please contact the nearest Infineon Technologies Office.

Infineon Technologies components may be used in life-support devices or systems only with the express written approval of Infineon Technologies, if a failure of such components can reasonably be expected to cause the failure of that life-support device or system or to affect the safety or effectiveness of that device or system. Life support devices or systems are intended to be implanted in the human body or to support and/or maintain and sustain and/or protect human life. If they fail, it is reasonable to assume that the health of the user or other persons may be endangered.

Revision History

Page or Item	Subjects (major changes since previous revision)
1.0	Initial Version
1.1	Modifications in chapter 7.1.4
1.2	Editorial Changes

Trademarks of Infineon Technologies AG

SOLID FLASH™ AXI™

Miscellaneous

The term "Mifare" in this document is only used as an indicator of product compatibility to the corresponding established technology. This applies to the entire document wherever the term is used.

Last Trademarks Update 2011-02-24

Content

1	Security Target Lite Introduction (ASE_INT)	6
1.1	Security Target and Target of Evaluation Reference	6
1.2	Target of Evaluation overview	12
2	Target of Evaluation Description	16
2.1	TOE Definition	16
2.2	Scope of the TOE	19
2.2.1	Hardware of the TOE.....	20
2.2.2	Firmware and software of the TOE	21
2.2.3	Interfaces of the TOE	22
2.2.4	Guidance documentation.....	23
2.2.5	Forms of delivery	24
2.2.6	Production sites	24
3	Conformance Claims (ASE_CCL)	25
3.1	CC Conformance Claim.....	25
3.2	PP Claim	25
3.3	Package Claim	25
3.4	Conformance Rationale	25
4	Security Problem Definition (ASE_SPD)	28
4.1	Threats	28
4.1.1	Additional Threat due to TOE specific Functionality	28
4.1.2	Assets regarding the Threats.....	29
4.2	Organizational Security Policies	30
4.2.1	Augmented Organizational Security Policy	30
4.3	Assumptions.....	31
4.3.1	Augmented Assumptions.....	32
5	Security objectives (ASE_OBJ)	33
5.1	Security objectives for the TOE	33
5.2	Security Objectives for the development and operational Environment.....	34
5.2.1	Clarification of “Usage of Hardware Platform (OE.Plat-Appl)”	34
5.2.2	Clarification of “Treatment of User Data (OE.Resp-Appl)”	35
5.2.3	Clarification of “Protection during Composite product manufacturing (OE.Process-Sec-IC)”.....	35
5.3	Security Objectives Rationale.....	35
6	Extended Component Definition (ASE_ECD)	37
6.1	Component “Subset TOE security testing (FPT_TST)”	37
6.2	Definition of FPT_TST.2	37
6.3	TSF self test (FPT_TST).....	38
7	Security Requirements (ASE_REQ)	39
7.1	TOE Security Functional Requirements.....	39
7.1.1	Extended Components FCS_RNG.1 and FAU_SAS.1	40
7.1.2	Subset of TOE testing	41
7.1.3	Memory access control.....	42
7.1.4	Support of Cipher Schemes.....	44
7.1.5	Data Integrity	51
7.2	TOE Security Assurance Requirements	52
7.2.1	Refinements	53
7.3	Security Requirements Rationale	53
7.3.1	Rationale for the Security Functional Requirements	53

7.3.2	Rationale of the Assurance Requirements.....	59
8	TOE Summary Specification (ASE_TSS)	61
8.1	SF_DPM: Device Phase Management	61
8.2	SF_PS: Protection against Snooping.....	62
8.3	SF_PMA: Protection against Modifying Attacks.....	63
8.4	SF_PLA: Protection against Logical Attacks.....	64
8.5	SF_CS: Cryptographic Support	65
8.5.1	3DES.....	65
8.5.2	AES.....	65
8.5.3	RSA.....	66
8.5.4	Elliptic Curves EC.....	67
8.5.5	SHA-2.....	68
8.5.6	Toolbox Library.....	68
8.5.7	Base Library	69
8.5.8	TRNG	69
8.6	Assignment of Security Functional Requirements to TOE's Security Functionality	70
8.7	Security Requirements are internally Consistent	71
9	References	72
9.1	Literature	72
10	Appendix	73
11	List of Abbreviations.....	75
12	Glossary.....	77

1 Security Target Lite Introduction (ASE_INT)

1.1 Security Target and Target of Evaluation Reference

The title of this document is Security Target Lite (ST) M7892 A21 and comprises the Infineon Technologies Security Controller M7892 A21 with specific IC dedicated software and optional RSA v1.02.013, EC v1.02.013, SHA-2 v1.01 and Toolbox v1.02.013 libraries.

The public Security Target Lite of evaluation (TOE) M7892 A21 is described in the following. The Security Target Lite has the revision 1.2 and is dated 2011-12-13.

The confidential Security Target of evaluation (TOE) M7892 A21 is subject of a non disclosure agreement. The confidential Security Target has the revision v0.7 and is dated 2011-12-12.

The Target of Evaluation (TOE) is an Infineon Security Controller M7892 A21 with optional RSA2048/4096 v1.02.013, EC v1.02.013, SHA-2 v1.01 and Toolbox v1.02.013 libraries and with specific IC dedicated software (firmware). The design step is A21

The Security Target is based on the Protection Profile “Smartcard IC Platform Protection Profile” [1].

The Protection Profile and the Security Target are built in compliance with Common Criteria v3.1.

The ST takes into account all relevant current final interpretations.

Table 1: Identification

	Version	Date	Registration
Security Target Lite	1.2	1.2	M7892 A21
Target of Evaluation	v1.02.013		M7892 A21 with FW-Identifier 78.015.14.0 and optional SW: RSA2048 v1.02.013 (optional) RSA4096 v1.02.013 (optional) EC v1.02.013 (optional) Toolbox v1.02.013 (optional) SHA-2 v1.01 (optional) and Guidance documentation
Guidance Documentation	v1.2	2011-12-12	M7892 Controller Family for Security Applications, Hardware Reference Manual
		2011-10-20	SLx 70 Family Production and Personalization, User's Manual
		2011-08-19	SLE 70 Family Programmer's Reference User's Manual
	v1.02.013	2011-06-07	SLE70 Asymmetric Crypto Library Crypto@2304T, RSA / ECC / Toolbox, Users Interface
		2009-11	Chipcard and Security ICs, SLx70 Family, Secure Hash Algorithm SHA-2, (SHA 256/224, SHA 512/384) (optional)
		2010-03-23	Crypto@2304T User Manual
	1.0	2011-11-18	AMM Advanced Mode for Mifare-Compatible Technology, Addendum to M7892 Hardware Reference Manual
		2011-12-12	M7892 Controller Security Guidelines User Manual
		2011-12-12	M7892 Errata Sheet
	v0.7	2011-12-12	Confidential Security Target
Protection Profile	1.0	2007-06-15	Security IC Platform Protection Profile PP0035
Common Criteria	3.1 Revision 3	2009-July	Common Criteria for Information Technology Security Evaluation Part 1: Introduction and general model CCMB-2009-07-001 Part 2: Security functional requirements CCMB-2009-07-002 Part 3: Security Assurance Components CCMB-2009-07-003

A customer can identify the TOE and its configuration using the Non-ISO ATR in combination with firmware functions. The TOE answers the Non-ISO-ATR with the Generic Chip Identification Mode (GCIM). The GCIM outputs a chip identifier byte, design step, firmware identifier version and further configuration information. The identification data and configuration details are described in the confidential Security Target [16] and in the [Family Hardware Reference Manual [7].

Remarks to the Target of Evaluation (TOE):

This TOE is represented by various products, differentiated by various configuration possibilities. Despite these configuration possibilities, all products are derived from the equal hardware design results, the M7892 A21.

All product derivatives are identically from module design, layout and footprint, but are different in their possibilities to connect to different types of antennas or in their ability to be implemented in special packages for different form factors. The TOE is represented and made out of different mask sets with following TOE internal and security irrelevant differences:

Various RFI input capacities at different derivatives are offered allowing the connection of a wide range of various antenna types, which are of course externally and not part of the TOE.

In addition, further order options are offered to serve also use cases different from the smart card form factor, for example for the implementation in printed circuit boards. This requires often a different package and reconnection of the connecting pads. For these TOE derivatives, an optional additional metal layer is implemented on top, where just the pads are reconnected to adapt to the individual special package respectively use case. This additional on top metal layer is comparable to an outer package, which simply reconnects the TOE pads in a different way.

This last reconnecting layer implements no functional change to the TOE itself, and, is in addition, subject of the design demands of the user. Therefore, this last layer is flexible in design and naming and of course, not relevant for the security of the TOE. It is comparable to the scenario where someone takes a piece of wire and reconnects the pads of a smartcard in a different way.

In contrast to the addition top layer, the various RFI input capacities are realized on a lower metal mask and result in different mask sets the TOE derivatives are build from. This different RFI input capacities allow the connection to a wider range of various antenna types which are externally and not part of the TOE. The additional top layer process uses one of the other mask sets and applies on top of the very last mask of the TOE an additional metal layer just reconnecting the pads.

For clear differentiation between the mask sets, each of it has assigned an individual value in the data output of the Generic Chip Identification Mode (GCIM). This is the only difference between the mask sets, the TOE is made of. Details are depicted in the user guidance hardware reference manual HRM, [7].

The M7892 A21 product allows for a maximum of configuration possibilities following the market needs. For example, a M7892 A21 product can come in one project with the fully available SOLID FLASH™¹ or in another project with any other SOLID FLASH™ -size below the physical implementation size, or with a different RAM size. And more, the user has the free choice, whether he needs the symmetric co-processor SCP, or the asymmetric co-processor Crypto2304T, or both, or none of them. In addition, the user decides, whether the TOE comes with a free combination of software libraries or without any. And, to be even more flexible, various interface options can be chosen as well. To sum up the major selections, the user defines by his order:

- the available memory sizes of the SOLID FLASH™ and RAM.
Note that there is no user available ROM on the TOE.
- the availability of the cryptographic coprocessors,

¹ SOLID FLASH™ is an Infineon Trade Mark and stands for Flash EEPROM technology.

- the availability and free combinations of the cryptographic libraries,
- the availability of the Flash Loader for available interfaces like ISO-7816, contactless ISO-14443
- the availability of various interface options, and
- the possibility to tailor the product by blocking on his own premises.

The degree of freedom of the chip configuration is predefined by Infineon Technologies AG and made available via the order tool.

Beside predefined fix TOE configurations, which can be ordered as usual, this TOE implements optionally the so called Billing-Per-Use (BPU) ability, also as order option. If offered, this solution enables the user to tailor a product on stock himself to the required configuration – project by project. By that BPU allows for significant reduction of logistic cost at all participating parties and serves for acceleration of delivery of tailored product to the end-user.

The blocking information can be modified by the users applying specific APDUs. Once final blocking is done, further modifications are disabled.

The BPU software part is only present on predefined products, which have been ordered with the BPU option. In all other cases this software is not present on the product. More details can be obtained in the confidential Security Target [16].

In addition, after strong and successful authentication, the Flash Loader firmware part allows the user to download his code, or just parts of it, to the SOLID FLASH™. This is of course given after delivery, at his own premises. Therefore, the user is entirely flexible in his process, regardless whether he intends to flash his code entirely on his own, or sends his complete code, or just parts of it to Infineon for high parallel flashing during production. After the flashing is completed the Flash Loader firmware is permanently deactivated.

Beside all configuration possibilities, it is self-evident that all security relevant settings are exclusively contained in the IFX-only part. Also the Flash Loader software does not access and has no access to the IFX-only part.

Once the TOE configuration is finished, the configuration page is no more accessible for changes. After the final deactivation of the Flash Loader, the product is also permanently fixed regarding its configurations and software. A reactivation of the Flash Loader is not possible. At the next start-up, the STS apply the settings, and, if called, a RMS-function can output the finally made chip configuration for verification and information purposes.

The entire configuration storage area is protected against manipulation, perturbation and false access. Note that the IFX-only part of the configuration page is already access protected prior delivery to the user and the TOE leaves the Infineon Technology premises only locked into User Mode.

Various delivery combinations are possible and described in the confidential Security Target [16].

Beside the various TOE configurations further possibilities of how the user inputs his software on the TOE, i.e. the operating system and applications, are in place. This provides a maximum of flexibility for the entire process of how users keep and manage their data. An overview is given in the following table:

Table 2: Options to implement user software at Infineon production premises

1.	The user or/and a subcontractor downloads the software into the SOLID FLASH™ flash memory on his own. Infineon Technologies has not received user software and there are no user data in the ROM.	The Flash Loader can be activated or reactivated by the user or subcontractor to download his software in the SOLID FLASH™ flash memory.
2	The user provides software for the download into the SOLID FLASH™ flash memory to Infineon Technologies AG. The software is downloaded to the SOLID FLASH™ flash memory during chip production. I.e. there are no user data in the ROM.	There is no Flash Loader present.
3	The user provides software for the download into the SOLID FLASH™ flash memory to Infineon Technologies AG. The software is downloaded to the SOLID FLASH™ flash memory during chip production. I.e. there are no user data in the ROM.	The Flash Loader is blocked afterwards but can be activated or reactivated by the user or subcontractor to download his software in the SOLID FLASH™ flash memory. Precondition is that the user has provided an own reactivation procedure in software prior chip production to Infineon Technologies AG.

The following listing contains a selection of configuration possibilities. More information is given in the confidential Security Target [16], Note that within those limitations the TOE configurations can vary under only one equal IC-hardware and one development code – the M7892 A21 – and without impact on security.

Note also that following configuration possibilities are valid unchanged throughout all different mask sets.

Table 3: Configuration ranges and blocking options for the user

Module / Feature (User view)	Max-Value (User view)	Min-Value (User view)	Blocking possible	Blocking Step
Memories				
SOLID FLASH™	Max. 404 kBytes	Min. 0 kBytes	Yes	1 kBytes
ROM	Not available	Not available	No	None
RAM for the user	8 kBytes	1 kBytes	Yes	1kBytes
Modules				
Crypto2304T	Available	Not available	Yes	On/off
SCP	Available	Not available	Yes	On/off
Interfaces				
ISO 7816-3 slave	Available	Not available	Yes	On/off
RFI – ISO 14443 generally	Available	Not available	Yes	On/off

Module / Feature (User view)	Max-Value (User view)	Min-Value (User view)	Blocking possible	Blocking Step
ISO 14443 Type A card mode	Available	Not available	By order only	None
ISO 14443 Type B card mode	Available	Not available	By order only	None
ISO 18092 NFC passive mode	Available	Not available	By order only	None
Mifare hardware support for card mode	Available	Not available	By order only	None
SW support for Mifare compatible 4k cards (1)	Available	Not available	By order only	None
SW support for Mifare compatible 1k cards (1)	Available	Not available	By order only	None

(1) Mifare emulation

All possible TOE configurations equal and/or within the below specified ranges are covered by the certificate.

Note that there is no user available on-chip ROM module anymore. The user software and data are now located in a dedicated and protected part of the SOLID FLASH™. The long life storage endurance, the automatic management of often used memory pages, together with the means for error detection and correction serves at least for equal or even higher reliability and endurance, compared to a dedicated ROM.

Beside the above listed flexible ranges, the user guidance contains a number of predefined configurations for those customers not making use of the BPU option. All of these configurations belong to the TOE as well and are of course made of the equal hardware and are inside the above declared ranges.

Today's predefined configurations of the TOE are listed in the hardware reference manual [7]. These predefined products come with the most requested configurations and allow to produce volumes on stock in order to simplify logistic processes.

According to the BPU option, a non limited number of configurations of the TOE may occur in the field. The number of various configurations depends on the order and purchase contract only.

Note that the TOE answers to the Non-ISO-ATR with the Generic Chip Identification Mode (GCIM) answer. This GCIM outputs a coded clear identifier for the type of the GCIM, the platform identifier, the design step and further configuration information. The confidential Security Target [16] and the hardware reference manual [7], being part of the user guidance, enables then for the clear interpretation of the read out GCIM data.

These GCIM data enable the user for clear identification of the TOE and also of one of the different mask sets and therewith for checking the validity of the certificate.

In addition, a dedicated RMS function allows reading out the present configuration in detail. Again, together with hardware reference manual [7], this allows for clear identification of a product and its configuration.

All these steps for gathering identification and detailed configuration information can be done by the user himself, without involving Infineon Technologies AG.

The TOE consists of the hardware part, the firmware parts and the software parts.

The software parts are differentiated into:

the cryptographic libraries RSA¹, EC² and SHA-2³ and the supporting libraries Toolbox and Base.

RSA, EC, SHA-2 and Toolbox provide certain functionality via an API to the Smartcard Embedded Software. The Base Library is only used internally by the RSA, EC and Toolbox libraries and has no user interface. If none of the three libraries RSA, EC and Toolbox is delivered, also the Base Library is not on board. The SHA-2 library does not use the Base Library.

The firmware parts are the RMS library, the Service Algorithm Minimal (SAM), the STS firmware for test purpose (see chapter 2.2.2), providing some functionality via an API to the Smartcard Embedded Software, the Flash Loader for downloading user software to the NVM and the Mifare compatible software interface. The STS is implemented in a separated Test-ROM being part of the TOE.

The Smartcard Embedded Software, i.e. the operating system and applications are not part of the TOE.

The TOE can be delivered including - in free combinations - or not including any of the functionality of the cryptographic libraries EC, RSA, SHA-2 and the supporting Toolbox library. If RSA or EC or Toolbox is delivered, automatically the Base Library is part of the shipment too.

If the user decides not to use one or all of the crypto library(s), the specific library(s) is (are) not delivered to the user and the accompanying "Additional Specific Security Functionality (O.Add-Functions)" *Rivest-Shamir-Adleman (RSA)* and/ or *EC* and/ or *SHA-2* is/are not provided by the TOE.

The Toolbox library provides the user optionally basic arithmetic and modular arithmetic operations, in order to support user software development using long integer operations. These basic arithmetic operations do not provide any security functionality, implement no security mechanism, and do not provide additional specific security functionality - as defined for the cryptographic libraries.

The user developed software using the Toolbox basic operations is not part of the TOE.

The Base Library provides the low level interface to the asymmetric cryptographic coprocessor and has no user available interface. The base library does not provide any security functionality, implements no security mechanism, and does not provide additional specific security functionality.

Deselecting one of the libraries does not include the code implementing functionality, which the user decided not to use. Not including the code of the deselected functionality has no impact of any other security policy of the TOE; it is exactly equivalent to the situation where the user decides just not to use the functionality.

The RSA, EC, SHA-2 and Toolbox libraries can be loaded, together with the Smartcard Embedded software, into the SOLID FLASH™. This holds also for the Base Library, if the RSA, EC or Toolbox or combinations hereof is/are part of the shipment.

All other Smartcard Embedded Software does not belong to the TOE and is not subject of the evaluation.

1.2 Target of Evaluation overview

The TOE comprises the Infineon Technologies Dual Interface Security Controller M7892 A21 with specific IC dedicated software and optional RSA, EC, SHA-2 and Toolbox libraries.

The TOE is a member of the Infineon Technologies AG high security controller family SLE70 meeting the highest requirements in terms of performance and security. The complete summary product description is given in the confidential Security Target [16]. This document provides an excerpt.

¹ Rivest-Shamir-Adleman asymmetric cryptographic algorithm

² The Elliptic Curve Cryptography is abbreviated with EC only in the further, in order to avoid conflicts with the abbreviation for the Error Correction Code ECC.

³ SHA Secure Hash Algorithm

The SLE70 family provides a common architecture upon which specific products can be tailored for markets ranging from basic security applications (SLE76) up to high security and contactless applications (SLE78).

The TOE is intended to be used in any applications and devices with highest security requirements. For example in smart cards and also in other applications, such as secure element in various devices. This new product family features a new security philosophy focusing on data integrity. By that three main principles combined in close synergy are utilized in the new security concept called the “Integrity Guard”. The Integrity Guard implements the main principles full error detection, full encryption and intelligent active shielding.

With these capabilities this TOE can be used almost everywhere, where highly secure applications are in use and of course in any other application as well. This TOE is deemed for governmental, corporate, transport and payment markets, or wherever a secure root of trust is required. Various types of applications can use this TOE, for example in closed loop logical access controls, physical access controls, secure internet access control and internet authentication, or as multi-application token or simply as encrypted storage.

This dual interface controller is able to communicate using either the contact based or the contactless interface. The implemented dual interface provides a maximum flexibility in using following communication protocols: ISO 7816, ISO 14443 Type A and Type B, ISO/IEC 18092 NFC passive mode, Mifare compatible Interface as well as further communication modes, allowing also the implementation of user defined concepts for contact based or contactless communication. More details are given the confidential Security Target [16] and the hardware reference manual [7].

In order to increase the contactless interface performance even more, the RFI can be configured in terms of baud rates for reception and transmission and the setting of the sub-carrier frequency used for the load modulation. More details are given in the hardware reference manual [7].

Table 4: Interface combinations excerpt of the TOE

Interface Options in brief					
Protocol	ISO7816	ISO14443 A	ISO14443 B	ISO18092 NFC passive mode	Mifare compatible interface

Further details and options are described in the confidential Security Target [16].

The TOE provides a real 16-bit CPU-architecture and is compatible to the Intel 80251 architecture. The major components of the core system are the two CPUs (Central Processing Units), the MMU (Memory Management Unit) and MED (Memory Encryption/Decryption Unit). The two CPUs control each other in order to detect faults and serve by this for data integrity. The TOE implements a full 16 MByte linear addressable memory space for each privilege level, a simple scalable Memory Management concept and a scalable stack size. The flexible memory concept consists of ROM- and Flash-memory as part of the non volatile memory (NVM), respectively SOLID FLASH™. For the SOLID FLASH™ memory the Unified Channel Programming (UCP) memory technology is used.

The RMS library providing some functionality via an API to the Smartcard Embedded Software contains for example SOLID FLASH™ service routines. The Service Algorithm provides functionality for the tearing save write into the SOLID FLASH™. The STS firmware is used for test purposes during start-up and the Flash Loader allows downloading user software to the NVM during the manufacturing process. The STS is implemented in a separated Test-ROM being part of the TOE.

The two cryptographic co-processors serve the need of modern cryptography: The symmetric co-processor (SCP) combines both AES and Triple-DES with dual-key or triple-key hardware acceleration. The Asymmetric Crypto Co-processor, called Crypto2304T in the following, is an

optimized version of the Crypto@1408 used in the SLE88-family with performance improvements for RSA-2048 bit (4096-bit with CRT) and Elliptic Curve (EC) cryptography.

The software part of the TOE consists of the cryptographic RSA-, EC- and the SHA-2 libraries and the supporting Toolbox and Base libraries. If RSA or EC or Toolbox or combinations hereof are part of the shipment, automatically the Base Library is included.

The RSA library is used to provide a high level interface to RSA (Rivest, Shamir, Adleman) cryptography implemented on the hardware component Crypto2304T and includes countermeasures against SPA, DPA and DFA attacks. The routines are used for the generation of RSA Key Pairs (RsaKeyGen), the RSA signature verification (RsaVerify), the RSA signature generation (RsaSign) and the RSA modulus recalculation (RsaModulus). The hardware Crypto2304T unit provides the basic long number calculations (add, subtract, multiply, square with 1100 bit numbers) with high performance. The RSA library is delivered as object code and in this way integrated in the user software. The RSA library can perform RSA operations from 512 to 4096 bits.

Following the BSI¹ recommendations, key lengths below 1024 bit are not included in the certificate.

The EC library is used to provide a high level interface to Elliptic Curve cryptography implemented on the hardware component Crypto2304T and includes countermeasures against SPA, DPA and DFA attacks. The routines are used for ECDSA signature generation, ECDSA signature verification, ECDSA key generation and Elliptic Curve Diffie-Hellman key agreement. In addition, the EC library provides an additional function for calculating primitive elliptic curve operations like EC Add and EC Double. EC curves over prime field F_p , as well as over $GF(2^n)$ finite field are supported too.

The EC library is delivered as object code and in this way integrated in the user software. The certification covers the standard NIST [14] and Brainpool [15] Elliptic Curves with key lengths of 192 to 521 Bits, due to national AIS32 regulations by the BSI. Note that there are numerous other curve types, being also secure in terms of side channel attacks on this TOE, which can the user optionally add in the composition certification process.

The SHA-library provides the calculation of a hash value of freely chosen data input in the CPU. The SHA-library is delivered as object code and is in this way available for the user software. This secure hash-algorithm SHA-2 is intended to be used for signature generation, verification and generic data integrity checks. The use for keyed hash operations like HMAC or similar security critical operations involving keys, is not subject of this TOE and requires specific security improvements and DPA analysis including the operating system, which is not part of this TOE.

The toolbox library does not provide cryptographic support or additional security functionality as it provides only the following basic long integer arithmetic and modular functions in software, supported by the cryptographic coprocessor: Addition, subtraction, division, multiplication, comparison, reduction, modular addition, modular subtraction, modular multiplication, modular inversion and modular exponentiation. No security relevant policy, mechanism or function is supported. The toolbox library is deemed for software developers as support for simplified implementation of long integer and modular arithmetic operations.

The Base Library provides the low level interface to the asymmetric cryptographic coprocessor and has no user available interface. The base library does not provide any security functionality, implements no security mechanism, and does not provide additional specific security functionality.

Note that this TOE can come with both cryptographic co-processors accessible, or with a blocked SCP or with a blocked Crypto2304T, or with both cryptographic co-processors blocked. The blocking depends on the user's choice. No accessibility of the deselected cryptographic co-processors is without impact on any other security policy of the TOE; it is exactly equivalent to the situation where the user decides just not to use the cryptographic co-processors. The TOE can be delivered without a specific library. In this case the TOE does not provide the Additional Specific Security Functionality Rivest-Shamir-Adleman Cryptography (RSA) or/and Elliptic Curve Cryptography (EC) or/and SHA-2.

¹ BSI Bundesamt für Sicherheit in der Informationstechnik – Federal office for information security

To fulfill the highest security standards for smartcards today and also in the future, this TOE represents an entirely new security concept. This TOE utilizes digital security features to include customer friendly security, combined with a robust design overcoming the disadvantages on analogue protection technologies. The TOE provides full on-chip encryption covering the complete core, busses, memories and cryptographic co-processors leaving no plaintext on the chip. Therefore the attractiveness for attackers is extremely reduced as encrypted signals are of no use for the attacker – neither for manipulation nor for eavesdropping.

In addition, the TOE is equipped with a full error detection capability for the complete data path. The dual CPU approach allows error detection even while processing. A comparator detects whether a calculation was performed without errors. This approach does not leave any parts of the circuitry unprotected. The concept allows that the relevant attack scenarios are detected, whereas other conditions that would not lead to an error would mainly be ignored. And more, the TOE is equipped with signal protection implemented by an Infineon-specific shielding combined with secure wiring of security critical signals. Subsequently, an intelligent shielding algorithm finishes the upper layers, finally providing the so called "I²-shield".

In the confidential Security Target [16] the TOE is described and a summary specification is given. The security environment of the TOE during its different phases of the lifecycle is defined. The assets are identified which have to be protected through the security policy. The threats against these assets are described. The security objectives and the security policy are defined, as well as the security requirements. These security requirements are built up of the security functional requirements as part of the security policy and the security assurance requirements. These are the steps during the evaluation and certification showing that the TOE meets the targeted requirements. In addition, the functionality of the TOE matching the requirements is described.

The assets, threats, security objectives and the security functional requirements are defined in this Security Target and in [1] and are referenced here. These requirements build up a minimal standard common for all Smartcards.

The security functions are defined here in the security target as property of this specific TOE. Here it is shown how this specific TOE fulfils the requirements for the standard defined in the Protection Profile [1].

2 Target of Evaluation Description

The TOE description helps to understand the specific security environment and the security policy. In this context the assets, threats, security objectives and security functional requirements can be employed. The following is a more detailed description of the TOE than in [1] as it belongs to the specific TOE.

2.1 TOE Definition

This TOE consists of Security Dual Interface Controllers as integrated circuits, meeting the highest requirements in terms of performance and security. They are manufactured by Infineon Technologies AG in a 90 nm CMOS-technology (L90). This TOE is intended to be used in smart cards for particularly security-relevant applications and for its previous use as developing platform for smart card operating systems according to the lifecycle model from [1]

The term Smartcard Embedded Software is used in the following for all operating systems and applications stored and executed on the TOE regardless whether it is a smartcard or another application of form factor. The TOE is the platform for the Smartcard Embedded Software. The Smartcard Embedded Software itself is not part of the TOE.

The TOE consists of a core system, memories, co-processors, peripherals, security modules and analogue peripherals. The major components of the core system are the two CPUs (Central Processing Units), the MMU (Memory Management Unit) and MED (Memory Encryption/Decryption Unit). The co-processor block contains the processors for RSA/EC and DES/AES processing, while the peripheral block contains the random number generation and the external interfaces service. The peripheral block contains also the timers and a watchdog. All data of the memory block is encrypted and all memory types are equipped with an error detection code (EDC), the SOLID FLASH™ in addition with an error correction code (ECC). The security modules serve for operation within the specified range and manage the alarms.

This dual interface controller is able to communicate using either the contact based or the contactless interface. The implemented dual interface provides a maximum flexibility in using following communication protocols: ISO 7816, ISO 14443 Type A and Type B, ISO/IEC 18092 NFC passive mode, Mifare compatible Interface as well as further communication modes, allowing also the implementation of user defined concepts for contact based or contactless communication.

The flexibility of the communication interfaces enable for example also the use cases involving external analogue modems, which are typically deemed for applications running in mobile devices. Please note that these external parts are of course not part of this TOE. More details are given the confidential Security Target [16] and the hardware reference manual [7].

The availability of the various communication options depends on the configuration and customer order.

Supporting a Mifare compatible Interface application requires a dedicated small space of memory. In this context and depending on user's choice, various memory sections of 1 up to 4 kByte each can be defined. The number and location of these memory sections is simply limited by the available SOLID FLASH™ space. Also these memory sections are read/write protected and are defined and generated by the user.

Note that there is a small set of sensors left in order to detect excessive deviations from the specified operational range, while not being over-sensitive. These digital features do not need adjustment or calibration and makes the chip even more robust. Conditions that would not be harmful for the operation would in most cases not influence the proper function. Having the integrity guard concept in place, the sensors are no more required for the TOE security. The sensors are assigned to be security supporting. The only sensors contributing to a security mechanism is the frequency sensor.

The CPU – here the two processors (CPU1 and CPU2) are seen from functional perspective as one - is compatible with the instruction set of the forerunner family 66-PE and is therefore also compatible to the SAB 80251 instruction set (8051 is a subset hereof) and is multiple times faster than the standard processor. It provides additional powerful instructions for smart card or other applications. It thus meets the requirements for the new generation of operating systems. Despite its compatibility the CPU implementation is entirely proprietary and not standard.

The CPU accesses the memory via the integrated Memory Encryption and Decryption unit (MED). The access rights of the application to the memories can be controlled with the memory management unit (MMU). Errors in the memories are automatically detected (EDC) and in terms of the SOLID FLASH™ 1-Bit-errors are also corrected (ECC). The two processors of the CPU control each other in order to detect faults and maintain by this the data integrity. A comparator detects whether a calculation was performed without errors and allows error detection even while processing. Therefore the TOE is equipped with a full error detection capability for the complete data path, which does not leave any parts of the circuitry unprotected.

The controllers of this TOE store both code and data in a linear 16-MByte memory space, allowing direct access without the need to swap memory segments in and out of memory using a memory management unit.

The error detection unit (EDU) automatically manages the error detection of the individual memories and detects incorrect transfer of data between the memories by means of error code comparison.

The CACHE memory – or simply, the CACHE – is a high-speed memory-buffer located between the CPU and the (external) main memories holding a copy of some of the memory contents to enable access to the copy, which is considerably faster than retrieving the information from the main memory. In addition to its fast access speed, the CACHE also consumes less power than the main memories. All CACHE systems own their usefulness to the principle of locality, meaning that programs are inclined to utilize a particular section of the address space for their processing over a short period of time. By including most or all of such a specific area in the CACHE, system performance can be dramatically enhanced. The implemented post failure detection identifies and manages errors if appeared during storage.

The TRNG is specially designed for smart cards, but can also be used in any other application where excellent physical random data are required. The TRNG fulfils the requirements from the functionality class P2 of the AIS31 and produces genuine random numbers which then can be used directly or as seed for the PRNG. The PRNG is not in the scope of the evaluation.

The implemented sleep mode logic (clock stop mode per ISO/IEC 7816-3) is used to reduce the overall power consumption. Contactless products provide a low-power halt mode for operation with reduced power.

The timer permits easy implementation of communication protocols such as T=1 and all other time-critical operations. The UART-controlled I/O interface allows the security controller and the terminal interface to be operated independently.

The Clock Unit (CLKU) supplies the clocks for all components of the TOE. The Clock Unit can work in an internal and external clock mode. When operating in the internal clock mode the system frequency may be varied in a range of approximately 1 MHz up to 33 MHz in steps of roughly 1 MHz. Some derivatives provide also frequencies beyond 33 MHz, which enables a programmer to choose the best-fitting frequency for an application in consideration of a potential current limit and a demanded application performance. In this external clock mode, the system clock is derived from an externally applied interface clock according to a defined dependency. The system frequency may be 1 up to 8 times the externally applied frequency but is of course limited to the maximum system frequency. More details are given in the confidential Security Target [16] and in the hardware reference manual [7].

Two co-processors for cryptographic operations are implemented on the TOE: The Crypto2304T for calculation of asymmetric algorithms like RSA and Elliptic Curve (EC) and the Symmetric Cryptographic Processor (SCP) for dual-key or triple-key triple-DES and AES calculations. These co-processors are especially designed for smart card applications with respect to the security and power consumption, but can of course be used in any other application of form factor where suitable. The SCP module computes the complete DES algorithm within a few clock cycles and is especially designed to counter attacks like DPA, EMA and DFA.

Note that this TOE can come with both crypto co-processors accessible, or with a blocked SCP or with a blocked Crypto2304T, or with both crypto co-processors blocked. The blocking depends on the customer demands prior to the production of the hardware. No accessibility of the deselected cryptographic co-processors is without impact on any other security policy of the TOE; it is exactly equivalent to the situation where the user decides just not to use the cryptographic co-processors.

The STS (self-test software), RMS (Resource Management System), Service Algorithm Minimal (SAM) and Flash Loader together compose the TOE firmware stored in the ROM and the patches hereof in the SOLID FLASH™. All mandatory functions for internal testing, production usage and start-up behavior (STS), and also the RMS and SAM functions are grouped together in a common privilege level. These privilege levels are protected by a hardwired Memory Management Unit (MMU) setting.

The user software can be implemented in various options depending on the user's choice and described in chapter 1.1. Thereby the user software, or parts of it, can be downloaded into the SOLID FLASH™, either during production of the TOE or at customer side. In the latter case, the user downloads his software or the final parts of it at his own premises, using the Flash Loader software.

The TOE uses also Special Function Registers SFR. These SFR registers are used for general purposes and chip configuration. The start-up register values are stored in the SOLID FLASH™, in the configuration page area.

The bus system comprises two separate bus entities: a memory bus supporting the AXI protocol (Advanced eXtensible Interface) and an APB (Advanced Peripheral Bus) for high-speed communication with the peripherals.

An intelligent shielding algorithm finishes the upper layers above security critical signals and wires, finally providing the so called "I²-shield".

The following is a list of features provided by this TOE:

- 24-bit linear addressing
- Up to 16 MByte of addressable memory
- Register-based architecture (registers can be accessed as bytes, words (2 bytes), and doublewords (4 bytes))
- 2-stage instruction pipeline
- Extensive set of powerful instructions, including 16- and 32-bit arithmetic and logic instructions
- CACHE with single-cycle access searching
- 16-bit ALU

The TOE sets a new, improved standard of integrated security features, thereby meeting the requirements of all smart card and other related applications or form factors, such as information integrity, access control, mobile telephone and identification, as well as uses in electronic funds transfer and healthcare systems.

To sum up, the TOE is a powerful dual interface security controller with a large amount of memory and special peripheral devices with improved performance, optimized power consumption, free to choose contact based or contactless operation, at minimal chip size while implementing high security. It therefore constitutes the basis for future smart card and other related applications or form factors.

Figure 1: Simplified block diagram of the TOE

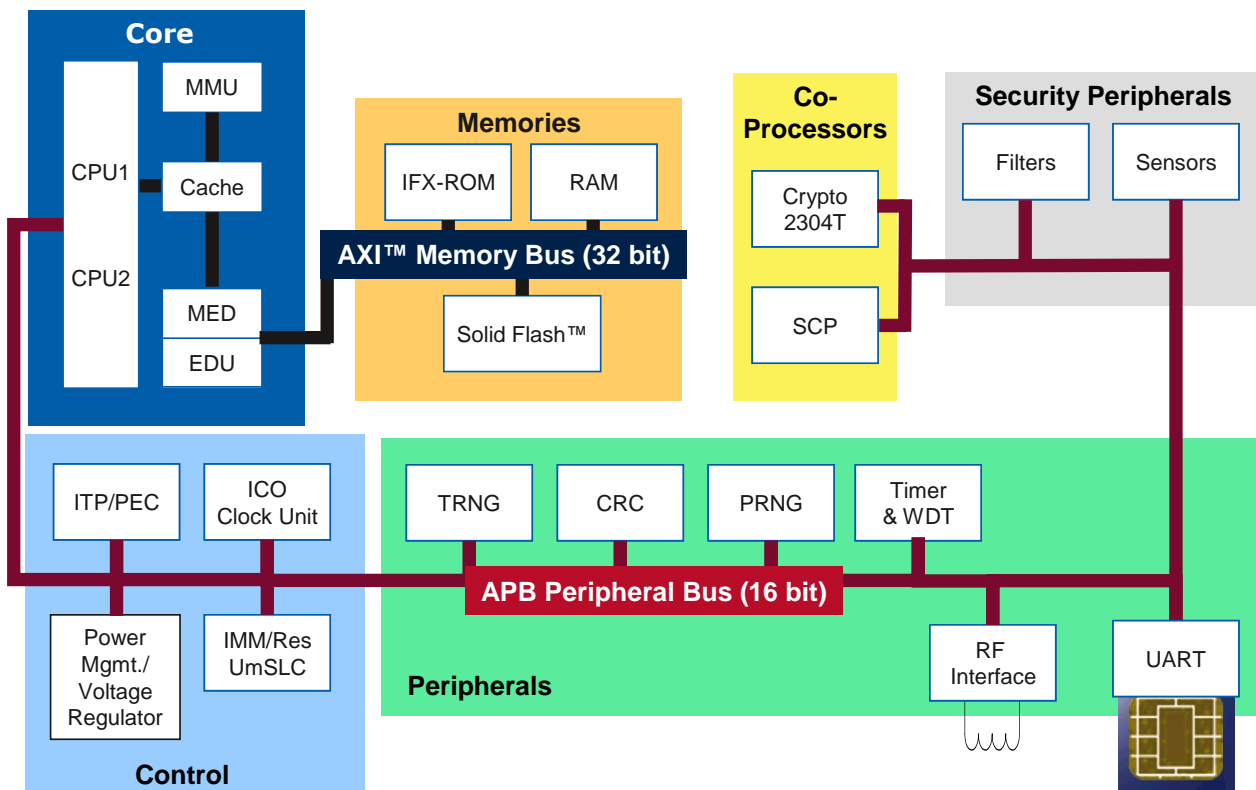

2.2 Scope of the TOE

The TOE comprises:

- The silicon die, respectively the IC or hardware, in several versions:
Each version differs from each other just by the input capacity of the RFI or by the additional metal layer on top
- with according firmware and
- optional software

of the security controller, as defined in the chapters above.

The TOE is delivered in various configurations, achieved by means of blocking.

All product derivatives of this TOE, including all configuration possibilities differentiated by the GCIM data and the configuration information output, are manufactured by Infineon Technologies AG. In the following descriptions, the term “manufacturer” stands short for Infineon Technologies AG, the manufacturer of the TOE.

New configurations can occur at any time, but in any case the user is able to clearly identify the TOE hardware, its configuration and proof the validity of the certificate independently, meaning without involving the manufacturer.

Entirely all means of blocking and the, for the blocking involved firmware respectively software parts, have been subject of the evaluation. All resulting configurations of a TOE derivative are subject of the certificate. All resulting configurations are either at the predefined limits or within the predefined configuration ranges.

The firmware used for the TOE internal testing and TOE operation, the firmware and software parts exclusively used for the blocking, the parts of the firmware and software required for cryptographic support are part of the TOE and therefore part of the certification. The documents as described in section 2.2.4 and listed in Table 1, are supplied as user guidance.

Not part of the TOE and not part of the certification are:

- the Smartcard Embedded Software respectively user software, and commercial parts of the Billing-Per-Use software.
- External antennas or other devices the TOE could be implemented.

2.2.1 Hardware of the TOE

The hardware part of the TOE (see Figure 1) as defined in [1] is comprised of:

Core System

Proprietary CPU implementation of the Intel MCS251 standard architecture from functional perspective, represented by two CPUs from hardware perspective

CACHE with Post Failure Detection

Memory Encryption/Decryption Unit (MED) and Error Detection Unit (EDU)

Memory Management Unit (MMU)

Memories

Read-Only Memory (IFX-ROM), not user available

Random Access Memory (RAM)

Electrical Erasable Programmable Read Only Memory (SOLID FLASH™)

Note that the TOE has only implemented an SOLID FLASH™ Flash memory module. Parts of this memory module are configured to work as an EEPROM.

Peripherals

True Random Number Generator (TRNG)

Pseudo Random Number Generator (PRNG)

Watchdog and Timers

Universal Asynchronous Receiver/Transmitter (UART)

Checksum module (CRC)

RF interface (radio frequency power and signal interface)

Control

Dynamic Power Management

Internal Clock Oscillator (ICO)

Interrupt and Peripheral Event Channel Controller (ITP and PEC)

Interface Management Module (IMM)

User mode Security Life Control (UmSLC)

Voltage Regulator

Coprocessors

Crypto2304T for asymmetric algorithms like RSA and EC (optionally blocked)

Symmetric Crypto Co-processor for 3DES and AES Standards (optionally blocked)

Security Peripherals

Filters

Sensors

Buses

AXI Memory Bus

APB Peripheral Bus

2.2.2 Firmware and software of the TOE

The entire firmware of the TOE consists of different parts:

One part comprises the RMS and SAM routines for SOLID FLASH™ programming, security functions test, and random number online testing (Resource Management System, IC Dedicated Support Software in PP [1]).

The RMS and SAM routines are stored from Infineon Technologies AG in the ROM. The ROM is only available for Infineon Technologies AG. The user has no access.

The second part is the STS, consisting of test and initialization routines (Self Test Software, IC Dedicated Test Software in PP [1]). The STS routines are stored in the especially protected test ROM and are not accessible for the user software.

The third part is the Flash Loader. A piece of software is located in the IFX-ROM and allows downloading the user software or parts of it to the SOLID FLASH™ memory. After completion of the download the Flash Loader can be permanently deactivated by the user.

The fourth part is the Mifare compatible Interface routines, called via RMS routines, if the related interface option is active. Note that these routines are always present, but are deactivated, in case of the derivatives coming without this option. Thus the user interface is identically in both cases and consequently the related interface routines can be called in each of the derivatives. In case the related interface routines are called in derivatives without this option, a dedicated error code is returned. In the other case the related function is performed.

All parts of the firmware above are combined together by the TOE generation process to a single file and stored then in the data files the TOE is produced from. This comprises the firmware files for the ROM, where only Infineon Technologies AG has access, as well as the data to be flashed in the SOLID FLASH™.

The optional software part of the TOE consists of the RSA-, the EC, the SHA-2 and the toolbox libraries.

The RSA library is used to provide a high level interface to the RSA cryptography implemented on the hardware component Crypto2304T and includes countermeasures against SPA, DPA and DFA attacks. The routines are used for the generation of RSA Key Pairs (RsaKeyGen), the RSA signature verification (RsaVerify), the RSA signature generation (RsaSign) and the RSA modulus recalculation (RsaModulus). The module provides the basic long number calculations (add, subtract, multiply, square with 1100 bit numbers) with high performance.

The RSA library is delivered as object code and in this way integrated in the user software. The RSA library can perform RSA operations from 512 to 4096 bits. Depending on the customer's choice, the

TOE can be delivered with the 4096 code portion or with the 2048 code portion only. The 2048 code portion is included in both. Part of the evaluation are the RSA straight operations with key length from 1024 bits to 2048 bits, and the RSA CRT¹ operations with key lengths of 1024 Bits to 4096 Bits.

The EC library is used to provide a high level interface to Elliptic Curve cryptography and includes countermeasures against SPA, DPA and DFA attacks. The routines are used for ECDSA signature generation, ECDSA signature verification, ECDSA key generation and Elliptic Curve Diffie-Hellman key agreement. In addition, the EC library provides an interface to an addition function for primitive elliptic curve operations like ECC Add and ECC Double. ECC curves over prime field F_p , as well as over $GF(2^n)$ finite field are supported too.

The EC library is delivered as object code and in this way integrated in the user software. The certification covers the standard NIST [14] and Brainpool [15] Elliptic Curves with key lengths of 192 to 521 Bits, due to national AIS32 regulations by the BSI. Note that numerous other curve types are also secure in terms of side channel attacks on this TOE, which the user can optionally add in the composition certification process.

The SHA-2 library provides the calculation of a hash value of freely chosen data input in the CPU. The SHA-2 library is delivered as object code and is in this way available for the user software. This secure hash-algorithm SHA-2 is intended to be used for signature generation, verification and generic data integrity checks. The use for keyed hash operations like HMAC or similar security critical operations involving keys, is not subject of this TOE and requires specific security improvements and DPA analysis including the operating system, which is not part of this TOE.

The toolbox library does not provide cryptographic support or additional security functionality as it provides only the following basic long integer arithmetic and modular functions in software, supported by the cryptographic coprocessor: Addition, subtraction, division, multiplication, comparison, reduction, modular addition, modular subtraction, modular multiplication, modular inversion and modular exponentiation. No security relevant policy, mechanism or function is supported. The toolbox library is deemed for software developers as support for simplified implementation of long integer and modular arithmetic operations.

The Base Library provides the low level interface to the asymmetric cryptographic coprocessor and has no user available interface. The base library does not provide any security functionality, implements no security mechanism, and does not provide additional specific security functionality.

Note 1:

The cryptographic libraries RSA, EC and SHA-2 are delivery options. Therefore the TOE may come with free combinations of or without these libraries. In the case of coming without one or any combination of these libraries the TOE does not provide the Additional Specific Security Functionality Rivest-Shamir-Adleman Cryptography (RSA) and/or Elliptic Curve Cryptography (EC) and/or SHA-2. End of note.

2.2.3 Interfaces of the TOE

- The physical interface of the TOE to the external environment is the entire surface of the IC.
- The electrical interface of the TOE to the external environment is constituted by the pads of the chip, particularly the contacted RES, I/O, CLK lines and supply lines VCC and GND, as well as by the contactless RF interface. The contact based communication is according to ISO 7816/ETSI/EMV. Further combinations involving the pads and parts of the RF interface are also possible and described in the confidential Security Target [16] and in the hardware reference manual [7].
- The RF interface (radio frequency power and signal interface) enables contactless communication between a PICC (proximity integration chip card, PICC) and a PCD

¹ CRT: Chinese Remainder Theorem

reader/writer (proximity coupling device, PCD).

Power supply is received and data are received or transmitted by an antenna which consists of a coil with a few turns directly connected to the IC. Depending on customer orders the contactless interface options are set by means of blocking either at Infineon premises or at the premises of the user. Note that further interface options are available and described in the confidential Security Target [16].

- The data-oriented I/O interface to the TOE is formed by the I/O pad and by the various RF options.
- The interface to the firmware is constituted by special registers used for hardware configuration and control (Special Function Registers, SFR).
- The interface of the TOE to the operating system is constituted on one hand by the RMS routine calls and on the other by the instruction set of the TOE.
- The interface of the TOE to the test routines is formed by the STS test routine call, i.e. entry to test mode (STS-TM entry).
- The interface to the RSA calculations is defined from the RSA library interface.
- The interface to the EC calculations is defined from the EC library interface
- The interface to the SHA-2 calculation is defined from the SHA-2 library interface.

Note that the interfaces to the cryptographic libraries (RSA, EC and SHA-2) are optionally depending on the customer order.

2.2.4 Guidance documentation

The guidance documentation consists of the:

- M7892, Controller Family for Security Applications, Hardware Reference Manual
- SLx 70 Family Production and Personalization
- SLE 70 Family Programmer's Reference User's Manual
- SLE 70 Asymmetric Crypto Library for Crypto@2304T, RSA, ECC, Toolbox, User Interface (optional), contains all interfaces of the cryptographic RSA- and EC libraries, as well as of the Toolbox library. This document is only delivered to the user in case the RSA library and/or the EC library and/or the Toolbox library is/are part of the delivered TOE.
- SLx 70 Family, Secure Hash Algorithm SHA-2, (SHA 256/224, SHA 512/384), Confidential Application Note, Library Version v1.02.013, contains all interfaces of the SHA-2 library and is only delivered to the user in case the SHA-2 library is part of the delivered TOE.
- Crypto@2304T User Manual, describing the architecture of cryptographic coprocessor on register level. It also provides a functional description of the register architecture, instruction set and gives programming guidance.
- M7892, Controller Security Guidelines User Manual. This document discusses and provides code examples of how the user can consider the secure programming recommendations.
- M7892, Errata Sheet. It can occur that the TOE or related documentation can be updated during the life cycle. This is reported to the users in the Errata Sheet [5] on a case by case basis.
- Advanced Mode for Mifare-Compatible Technology. This user guidance describes the interface and how to use this communication mode.

Finally the certification report may contain an overview of the recommendations to the software developer regarding the secure use of the TOE. These recommendations are also included in the ordinary documentation.

2.2.5 Forms of delivery

The TOE can be delivered in any form of complete module, package, with or without inlay mounting, in form of plain wafers or in an IC case (e.g. DSO20) or in bare dies. The delivery can therefore be at the end of phase 3 or at the end of phase 4 which can also include pre-personalization steps according to PP [1]. Nevertheless in both cases the TOE is finished and the extended test features are removed. In this document are always both cases mentioned to avoid incorrectness but from the security policy point of view the two cases are identical.

The delivery to the software developer (phase 2 → phase 1) contains the development package and is delivered in form of documentation as described above, data carriers containing the tools and emulators as development and debugging tool.

Part of the software delivery is also the Flash Loader program, provided by Infineon Technologies, running on the TOE and receiving via the UART interface the transmitted information of the user software to be loaded into the SOLID FLASH™ flash memory. The download is only possible after successful authentication. The user software can also be downloaded in an encrypted way. In addition, the user can permanently block further use of the Flash Loader.

2.2.6 Production sites

The TOE may be handled in different production sites but the silicon of this TOE is produced in Dresden, Germany only. To distinguish the different production sites of various products in the field, the site is coded into the Generic Chip Ident Mode (GCIM) data. The exact coding of the generic chip identification data is described in the hardware reference manual, [7].

The delivery measures are described in the ALC_DVS aspect.

3 Conformance Claims (ASE_CCL)

3.1 CC Conformance Claim

This Security Target (ST) and the TOE claim conformance to Common Criteria version v3.1 part 1 [2], part 2 [3] and part 3 [4].

Conformance of this ST is claimed for:
Common Criteria part 2 extended and Common Criteria part 3 conformant.

3.2 PP Claim

This Security Target is in **strict conformance** to the Security IC Platform Protection Profile [1].

The Security IC Platform Protection Profile is registered and certified by the Bundesamt für Sicherheit in der Informationstechnik¹ (BSI) under the reference BSI-PP-0035, Version 1.0, dated 15.06.2007.

The security assurance requirements of the TOE are according to the Security IC Platform Protection Profile [1]. They are all drawn from Part 3 of the Common Criteria version v3.1.

The augmentations of the PP [1] are listed below.

Table 5: Augmentations of the assurance level of the TOE

Assurance Class	Assurance components	Description
Life-cycle support	ALC_DVS.2	Sufficiency of security measures
Vulnerability assessment	AVA_VAN.5	Advanced methodical vulnerability analysis

3.3 Package Claim

This Security Target does not claim conformance to a package of the PP [1].

The assurance level for the TOE is EAL5 augmented with the components ALC_DVS.2 and AVA_VAN.5.

3.4 Conformance Rationale

This security target claims strict conformance only to one PP, the PP [1].

The Target of Evaluation (TOE) is a typical security IC as defined in PP chapter 1.2.2 comprising:

- the circuitry of the IC (hardware including the physical memories),
- configuration data, initialization data related to the IC Dedicated Software and the behavior of the security functionality
- the IC Dedicated Software with the parts

¹ Bundesamt für Sicherheit in der Informationstechnik (BSI) is the German Federal Office for Information Security

- the IC Dedicated Test Software,
- the IC Dedicated Support Software.

The TOE is designed, produced and/or generated by the TOE Manufacturer.

Security Problem Definition:

Following the PP [1], the security problem definition is enhanced by adding an additional threat, an organization security policy and an augmented assumption. Including these add-ons, the security problem definition of this security target is consistent with the statement of the security problem definition in the PP [1], as the security target claimed strict conformance to the PP [1].

Conformance Rationale:

The augmented organizational security policy P.Add-Functions, coming from the additional security functionality of the cryptographic libraries, the augmented assumption A.Key-Function, related to the usage of key-depending function, and the threat memory access violation T.Mem-Access, due to specific TOE memory access control functionality, have been added. These add-ons have no impact on the conformance statements regarding CC [2] and PP [1], with following rational:

- The security target remains conformant to CC [2], claim 482 as the possibility to introduce additional restrictions is given.
- The security target fulfils the strict conformance claim of the PP [1] due to the application notes 5, 6 and 7 which apply here. By those notes the addition of further security functions and security services are covered, even without deriving particular security functionality from a threat but from a policy.

Due to additional security functionality, one coming from the cryptographic libraries - O.Add-Functions, and due to the memory access control - O.Mem-Access, additional security objectives have been introduced. These add-ons have no impact on the conformance statements regarding CC [2] and PP [1], with following rational:

- The security target remains conformant to CC [2], claim 482 as the possibility to introduce additional restrictions is given.
- The security target fulfils the strict conformance of the PP [1] due to the application note 9 applying here. This note allows the definition of high-level security goals due to further functions or services provided to the Security IC Embedded Software.

Therefore, the security objectives of this security target are consistent with the statement of the security objectives in the PP [1], as the security target claimed strict conformance to the PP [1].

All security functional requirements defined in the PP [1] are included and completely defined in this ST. The security functional requirements listed in the following are all taken from Common Criteria part 2 [3] and additionally included and completely defined in this ST:

- FDP_ACC.1 "Subset access control"
- FDP_ACF.1 "Security attribute based access control"
- FMT_MSA.1 "Management of security attributes"
- FMT_MSA.3 "Static attribute initialisation"
- FMT_SMF.1 "Specification of Management functions"
- FCS_COP.1 "Cryptographic support"
- FCS_CKM.1 "Cryptographic key generation"
- FDP_SDI.1 "Stored data integrity monitoring"

- FDP_SDI.2 “Stored data integrity monitoring and action

The security functional requirement

- FPT_TST.2 “Subset TOE security testing“(Requirement from [3])

is included and completely defined in this ST, section 6.

All assignments and selections of the security functional requirements are done in the PP [1] and in this security target in section 7.2.

The Assurance Requirements of the TOE obtain the Evaluation Assurance Level 5 augmented with the assurance components ALC_DVS.2 and AVA_VAN.5 for the TOE.

4 Security Problem Definition (ASE_SPD)

The content of the PP [1] applies to this chapter completely.

4.1 Threats

The threats are directed against the assets and/or the security functions of the TOE. For example, certain attacks are only one step towards a disclosure of assets while others may directly lead to a compromise of the application security. The more detailed description of specific attacks is given later on in the process of evaluation and certification. An overview on attacks is given in PP [1] section 3.2.

The threats to security are defined and described in PP [1] section 3.2.

Table 6: Threats according PP [1]

T.Phys-Manipulation	Physical Manipulation
T.Phys-Probing	Physical Probing
T.Malfunction	Malfunction due to Environmental Stress
T.Leak-Inherent	Inherent Information Leakage
T.Leak-Forced	Forced Information Leakage
T.Abuse-Func	Abuse of Functionality
T.RND	Deficiency of Random Numbers

4.1.1 Additional Threat due to TOE specific Functionality

The additional functionality of introducing sophisticated privilege levels and access control allows the secure separation between the operation system(s) and applications, the secure downloading of applications after personalization and enables multitasking by separating memory areas and performing access controls between different applications. Due to this additional functionality “area based memory access control” a new threat is introduced.

The Smartcard Embedded Software is responsible for its User Data according to the assumption “Treatment of User Data (A.Resp-App)”. However, the Smartcard Embedded Software may comprise different parts, for instance an operating system and one or more applications. In this case, such parts may accidentally or deliberately access data (including code) of other parts, which may result in a security violation.

The TOE shall avert the threat “Memory Access Violation (T.Mem-Access)” as specified below.

T.Mem-Access Memory Access Violation

Parts of the Smartcard Embedded Software may cause security violations by accidentally or deliberately accessing restricted data (which may include code) or privilege levels. Any restrictions are defined by the security policy of the specific application context and must be implemented by the Smartcard Embedded Software.

Table 7: Additional threats due to TOE specific functions and augmentations

T.Mem-Access	Memory Access Violation
--------------	-------------------------

For details see PP [1] section 3.2.

4.1.2 Assets regarding the Threats

The primary assets concern the User Data which includes the user data as well as program code (Security IC Embedded Software) stored and in operation and the provided security services. These assets have to be protected while being executed and or processed and on the other hand, when the TOE is not in operation.

This leads to four primary assets with its related security concerns:

- SC1 Integrity of User Data and of the Security IC Embedded Software (while being executed/processed and while being stored in the TOE's memories),
- SC2 Confidentiality of User Data and of the Security IC Embedded Software (while being processed and while being stored in the TOE's memories)
- SC3 Correct operation of the security services provided by the TOE for the Security IC Embedded Software.
- SC4 Continuous availability of random numbers

SC4 is an additional security service provided by this TOE which is the availability of random numbers. These random numbers are generated either by a true random number or a deterministic random number generator or by both, when a true random number is used as seed for the deterministic random number generator. Note that the generation of random numbers is a requirement of the PP [1].

To be able to protect the listed assets the TOE shall protect its security functionality as well. Therefore critical information about the TOE shall be protected. Critical information includes:

- logical design data, physical design data, IC Dedicated Software, and configuration data
- Initialisation Data and Pre-personalisation Data, specific development aids, test and characterisation related data, material for software development support, and reticles.

The information and material produced and/or processed by the TOE Manufacturer in the TOE development and production environment (Phases 2 up to TOE Delivery) can be grouped as follows:

- logical design data,
- physical design data,
- IC Dedicated Software, Security IC Embedded Software, Initialisation Data and Pre-personalisation Data,
- specific development aids,
- test and characterisation related data,
- material for software development support, and
- reticles and products in any form

as long as they are generated, stored, or processed by the TOE Manufacturer.

For details see PP [1] section 3.1.

4.2 Organizational Security Policies

The TOE has to be protected during the first phases of their lifecycle (phases 2 up to TOE delivery which can be after phase 3 or phase 4). Later on each variant of the TOE has to protect itself. The organisational security policy covers this aspect.

P.Process-TOE Protection during TOE Development and Production

An accurate identification must be established for the TOE. This requires that each instantiation of the TOE carries this unique identification.

The organisational security policies are defined and described in PP [1] section 3.3. Due to the augmentations of PP [1] an additional policy is introduced and described in the next chapter.

Table 8: Organizational Security Policies according PP [1]

P.Process-TOE	Protection during TOE Development and Production
---------------	--

4.2.1 Augmented Organizational Security Policy

Due to the augmentations of the PP [1] an additional policy is introduced.

The TOE provides specific security functionality, which can be used by the Smartcard Embedded Software. In the following specific security functionality is listed which is not derived from threats identified for the TOE's environment because it can only be decided in the context of the smartcard application, against which threats the Smartcard Embedded Software will use the specific security functionality.

The IC Developer / Manufacturer must apply the policy "Additional Specific Security Functionality (P.Add-Functions)" as specified below.

P.Add-Functions Additional Specific Security Functionality

The TOE shall provide the following specific security functionality to the Smartcard Embedded Software:

- Advanced Encryption Standard (AES)
- Triple Data Encryption Standard (3DES)
- Rivest-Shamir-Adleman Cryptography (RSA),
- Elliptic Curve Cryptography (EC)
- Secure Hash Algorithm SHA-2

Note 2:

The cryptographic libraries RSA, EC, SHA-2 and the Toolbox library are delivery options. Therefore the TOE may come with free combinations of or even without these libraries. In the case of coming without one or any combination of the cryptographic libraries RSA, EC and SHA-2, the TOE does not provide the Additional Specific Security Functionality Rivest-Shamir-Adleman Cryptography (RSA) and/or Elliptic Curve Cryptography (EC) and/or SHA-2. The Toolbox library is no cryptographic library and provides no additional specific security functionality. If RSA, EC or Toolbox are part of the shipment, the Base Library is automatically included. The Base Library does not provide additional specific functionality.

End of note.

Note 3:

This TOE can come with both crypto co-processors accessible, or with a blocked SCP or with a

blocked Crypto2304T, or with both crypto co-processors blocked. The blocking depends on the customer demands prior to the production of the hardware. In case the SCP is blocked, no AES and 3DES computation supported by hardware is possible. In case the Crypto2304T is blocked, no RSA and EC computation supported by hardware is possible. The use of the SHA-2 library is also possible with both crypto coprocessors blocked. No accessibility of the deselected cryptographic co-processors is without impact on any other security policy of the TOE; it is exactly equivalent to the situation where the user decides just not to use the cryptographic co-processors.
End of note.

4.3 Assumptions

The TOE assumptions on the operational environment are defined and described in PP [1] section 3.4.

The assumptions concern the phases where the TOE has left the chip manufacturer.

A.Process-Sec-IC Protection during Packaging, Finishing and Personalization

It is assumed that security procedures are used after delivery of the TOE by the TOE Manufacturer up to delivery to the end-consumer to maintain confidentiality and integrity of the TOE and of its manufacturing and test data (to prevent any possible copy, modification, retention, theft or unauthorised use).

A.Plat-Appl Usage of Hardware Platform

The Security IC Embedded Software is designed so that the requirements from the following documents are met: (i) TOE guidance documents (refer to the Common Criteria assurance class AGD) such as the hardware data sheet, and the hardware application notes, and (ii) findings of the TOE evaluation reports relevant for the Security IC Embedded Software as documented in the certification report.

A.Resp-Appl Treatment of User Data

All User Data are owned by Security IC Embedded Software. Therefore, it must be assumed that security relevant User Data (especially cryptographic keys) are treated by the Security IC Embedded Software as defined for its specific application context.

The support of cipher schemas needs to make an additional assumption.

Table 9: Assumption according PP [1]

A.Process-Sec-IC	Protection during Packaging, Finishing and Personalization
A.Plat-Appl	Usage of Hardware Platform
A.Resp-Appl	Treatment of User Data

4.3.1 Augmented Assumptions

The developer of the Smartcard Embedded Software must ensure the appropriate “Usage of Key-dependent Functions (A.Key-Function)” while developing this software in Phase 1 as specified below.

A.Key-Function	Usage of Key-dependent Functions
----------------	----------------------------------

Key-dependent functions (if any) shall be implemented in the Smartcard Embedded Software in a way that they are not susceptible to leakage attacks (as described under T.Leak-Inherent and T.Leak-Forced).

Note that here the routines which may compromise keys when being executed are part of the Smartcard Embedded Software. In contrast to this the threats T.Leak-Inherent and T.Leak-Forced address (i) the cryptographic routines which are part of the TOE

For details see PP [1] section 3.4.

5 Security objectives (ASE_OBJ)

This section shows the subjects and objects where are relevant to the TOE.
A short overview is given in the following.

The user has the following standard high-level security goals related to the assets:

- SG1 maintain the integrity of User Data and of the Security IC Embedded Software
- SG2 maintain the confidentiality of User Data and of the Security IC Embedded Software
- SG3 maintain the correct operation of the security services provided by the TOE for the Security IC Embedded Software
- SG4 provision of random numbers.

5.1 Security objectives for the TOE

The security objectives of the TOE are defined and described in PP [1] section 4.1.

Table 10: Objectives for the TOE according to PP [1]

O.Phys-Manipulation	Protection against Physical Manipulation
O.Phys-Probing	Protection against Physical Probing
O.Malfunction	Protection against Malfunction
O.Leak-Inherent	Protection against Inherent Information Leakage
O.Leak-Forced	Protection against Forced Information Leakage
O.Abuse-Func	Protection against Abuse of Functionality
O.Identification	TOE Identification
O.RND	Random Numbers

The TOE provides “Additional Specific Security Functionality (O.Add-Functions)” as specified below.

O.Add-Functions Additional Specific Security Functionality

The TOE must provide the following specific security functionality to the Smartcard Embedded Software:

- Advanced Encryption Standard (AES)
- Triple Data Encryption Standard (3DES),
- Rivest-Shamir-Adleman (RSA)
- Elliptic Curve Cryptography (EC)
- Secure Hash Algorithm (SHA-2)

Note 4:

The cryptographic libraries RSA, EC, SHA-2 and the Toolbox library are delivery options. If one of the libraries RSA, EC and Toolbox or combination hereof are delivered, the Base Lib is automatically part of it. Therefore the TOE may come with free combinations of or even without these libraries. In the

case of coming without one or any combination of the cryptographic libraries RSA, EC and SHA-2, the TOE does not provide the Additional Specific Security Functionality Rivest-Shamir-Adleman Cryptography (RSA) and/or Elliptic Curve Cryptography (EC) and/or SHA-2. The Toolbox and Base Library are no cryptographic libraries and provide no additional specific security functionality.

End of note.

Note 5:

This TOE can come with both crypto co-processors accessible, or with a blocked SCP or with a blocked Crypto2304T, or with both crypto co-processors blocked. The blocking depends on the customer demands prior to the production of the hardware. In case the SCP is blocked, no AES and 3DES computation supported by hardware is possible. In case the Crypto2304T is blocked, no RSA and EC computation supported by hardware is possible. The use of the SHA-2 library is also possible with both crypto coprocessors blocked. No accessibility of the deselected cryptographic co-processors is without impact on any other security policy of the TOE; it is exactly equivalent to the situation where the user decides just not to use the cryptographic co-processors.

End of note.

The TOE shall provide “Area based Memory Access Control (O.Mem-Access)” as specified below.

O.Mem-Access Area based Memory Access Control

The TOE must provide the Smartcard Embedded Software with the capability to define restricted access memory areas. The TOE must then enforce the partitioning of such memory areas so that access of software to memory areas and privilege levels is controlled as required, for example, in a multi-application environment.

Table 11: Additional objectives due to TOE specific functions and augmentations

O.Add-Functions	Additional specific security functionality
O.Mem-Access	Area based Memory Access Control

5.2 Security Objectives for the development and operational Environment

The security objectives for the security IC embedded software development environment and the operational environment is defined in PP [1] section 4.2 and 4.3. The table below lists the security objectives.

Table 12: Security objectives for the environment according to PP [1]

Phase 1	OE.Plat-Appl	Usage of Hardware Platform
	OE.Resp-Appl	Treatment of User Data
Phase 5 – 6 optional Phase 4	OE.Process-Sec-IC	Protection during composite product manufacturing

5.2.1 Clarification of “Usage of Hardware Platform (OE.Plat-Appl)”

Regarding the cryptographic services this objective of the environment has to be clarified. The TOE supports cipher schemes as additional specific security functionality. If required the Smartcard Embedded Software shall use these cryptographic services of the TOE and their interface as specified. When key-dependent functions implemented in the Smartcard Embedded Software are just

being executed, the Smartcard Embedded Software must provide protection against disclosure of confidential data (User Data) stored and/or processed in the TOE by using the methods described under “Inherent Information Leakage (T.Leak-Inherent)” and “Forced Information Leakage (T.Leak-Forced)”.

The objectives of the environment regarding the memory, software and firmware protection and the SFR and peripheral-access-rights-handling have to be clarified. For the separation of different applications the Smartcard Embedded Software (Operating System) may implement a memory management scheme based upon security functions of the TOE.

5.2.2 Clarification of “Treatment of User Data (OE.Resp-App)”

Regarding the cryptographic services this objective of the environment has to be clarified. By definition cipher or plain text data and cryptographic keys are User Data. The Smartcard Embedded Software shall treat these data appropriately, use only proper secret keys (chosen from a large key space) as input for the cryptographic function of the TOE and use keys and functions appropriately in order to ensure the strength of cryptographic operation.

This means that keys are treated as confidential as soon as they are generated. The keys must be unique with a very high probability, as well as cryptographically strong. For example, it must be ensured that it is beyond practicality to derive the private key from a public key if asymmetric algorithms are used. If keys are imported into the TOE and/or derived from other keys, quality and confidentiality must be maintained. This implies that appropriate key management has to be realised in the environment.

Regarding the memory, software and firmware protection and the SFR and peripheral access rights handling these objectives of the environment has to be clarified. The treatment of User Data is also required when a multi-application operating system is implemented as part of the Smartcard Embedded Software on the TOE. In this case the multi-application operating system should not disclose security relevant user data of one application to another application when it is processed or stored on the TOE.

5.2.3 Clarification of “Protection during Composite product manufacturing (OE.Process-Sec-IC)”

The protection during packaging, finishing and personalization includes also the personalization process (Flash Loader software) and the personalization data (TOE software components) during Phase 4, Phase 5 and Phase 6.

5.3 Security Objectives Rationale

The security objectives rationale of the TOE are defined and described in PP [1] section 4.4. For organizational security policy P.Add-Functions, OE.Plat-AppI and OE.Resp-AppI the rationale is given in the following description.

Table 13: Security Objective Rationale

Assumption, Threat or Organisational Security Policy	Security Objective
P.Add-Functions	O.Add-Functions
A.Key-Function	OE.Plat-AppI OE.Resp-AppI
T.Mem-Access	O.Mem-Access

The justification related to the security objective “Additional Specific Security Functionality (O.Add-Functions)” is as follows: Since O.Add-Functions requires the TOE to implement exactly the same specific security functionality as required by P.Add-Functions; the organisational security policy is covered by the objective.

Nevertheless the security objectives O.Leak-Inherent, O.Phys-Probing, O.Malfunction, O.Phys-Manipulation and O.Leak-Forced define how to implement the specific security functionality required by P.Add-Functions. (Note that these objectives support that the specific security functionality is provided in a secure way as expected from P.Add-Functions.) Especially O.Leak-Inherent and O.Leak-Forced refer to the protection of confidential data (User Data or TSF data) in general. User Data are also processed by the specific security functionality required by P.Add-Functions.

Compared to PP [1] clarification has been made for the security objective “Usage of Hardware Platform (OE.Plat-Appl)”: If required the Smartcard Embedded Software shall use these cryptographic services of the TOE and their interface as specified. In addition, the Smartcard Embedded Software must implement functions which perform operations on keys (if any) in such a manner that they do not disclose information about confidential data. The non disclosure due to leakage A.Key-Function attacks is included in this objective OE.Plat-Appl. This addition ensures that the assumption A.Plat-Appl is still covered by the objective OE.Plat-Appl although additional functions are being supported according to O.Add-Functions.

Compared to the PP [1] a clarification has been made for the security objective “Treatment of User Data (OE.Resp-Appl)”: By definition cipher or plain text data and cryptographic keys are User Data. So, the Smartcard Embedded Software will protect such data if required and use keys and functions appropriately in order to ensure the strength of cryptographic operation. Quality and confidentiality must be maintained for keys that are imported and/or derived from other keys. This implies that appropriate key management has to be realised in the environment. That is expressed by the assumption A.Key—Function which is covered from OE.Resp—Appl. These measures make sure that the assumption A.Resp-Appl is still covered by the security objective OE.Resp-Appl although additional functions are being supported according to P.Add-Functions.

Compared to the PP [1] an enhancement regarding memory area protection has been established. The clear definition of privilege levels for operated software establishes the clear separation of different restricted memory areas for running the firmware, downloading and/or running the operating system and to establish a clear separation between different applications. Nevertheless, it is also possible to define a shared memory section where separated applications may exchange defined data. The privilege levels clearly define by using a hierarchical model the access right from one level to the other. These measures ensure that the threat T.Mem-Access is clearly covered by the security objective O.Mem-Access.

The justification of the additional policy and the additional assumption show that they do not contradict to the rationale already given in the Protection Profile for the assumptions, policy and threats defined there.

6 Extended Component Definition (ASE_ECD)

There are four extended components defined and described for the TOE:

- the family **FCS_RNG** at the class FCS Cryptographic Support
- the family **FMT_LIM** at the class FMT Security Management
- the family **FAU_SAS** at the class FAU Security Audit
- the component **FPT_TST.2** at the class FPT Protection of the TSF

The extended components FCS_RNG, FMT_LIM and FAU_SAS are defined and described in PP [1] section 5. The component FPT_TST.2 is defined in the following.

6.1 Component “Subset TOE security testing (FPT_TST)”

The security is strongly dependent on the correct operation of the security functions. Therefore, the TOE shall support that particular security functions or mechanisms are tested in the operational phase (Phase 7). The tests can be initiated by the Smartcard Embedded Software and/or by the TOE or is done automatically and continuously.

Part 2 of the Common Criteria provides the security functional component “TSF testing (FPT_TST.1)”. The component FPT_TST.1 provides the ability to test the TSF’s correct operation.

For the user it is important to know which security functions or mechanisms can be tested. The functional component FPT_TST.1 does not mandate to explicitly specify the security functions being tested. In addition, FPT_TST.1 requires verification of the integrity of TSF data and of the stored TSF executable code which might violate the security policy. Therefore, the functional component “**Subset TOE security testing (FPT_TST.2)**” of the family TSF self test has been newly created. This component allows that particular parts of the security mechanisms and functions provided by the TOE are tested.

6.2 Definition of FPT_TST.2

The functional component “Subset TOE security testing (FPT_TST.2)” has been newly created (Common Criteria Part 2 extended). This component allows that particular parts of the security mechanisms and functions provided by the TOE can be tested after TOE Delivery or are tested automatically and continuously during normal operation transparent for the user. This security functional component is used instead of the functional component FPT_TST.1 from Common Criteria Part 2. For the user it is important to know which security functions or mechanisms can be tested. The functional component FPT_TST.1 does not mandate to explicitly specify the security functions being tested. In addition, FPT_TST.1 requires verifying the integrity of TSF data and stored TSF executable code which might violate the security policy.

The functional component “Subset TOE testing (FPT_TST.2)” is specified as follows (Common Criteria Part 2 extended).

6.3 TSF self test (FPT_TST)

Family Behavior The Family Behavior is defined in [3] section 15.14 (442, 443).

Component leveling

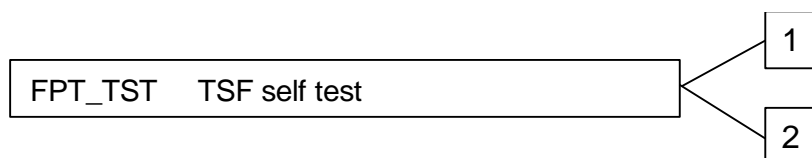

FPT_TST.1: The component FPT_TST.1 is defined in [3] section 15.14 (444, 445, 446).

FPT_TST.2: Subset TOE security testing, provides the ability to test the correct operation of particular security functions or mechanisms. These tests may be performed at start-up, periodically, at the request of the authorized user, or when other conditions are met. It also provides the ability to verify the integrity of TSF data and executable code.

Management: FPT_TST.2

The following actions could be considered for the management functions in FMT:

- management of the conditions under which subset TSF self testing occurs, such as during initial start-up, regular interval or under specified conditions
- management of the time of the interval appropriate.

Audit: FPT_TST.2

There are no auditable events foreseen.

FPT_TST.2 Subset TOE testing

Hierarchical to: No other components.

Dependencies: No dependencies.

FPT_TST.2.1: The TSF shall run a suite of self tests [selection: during initial start-up, periodically during normal operation, at the request of the authorized user, and/or at the conditions [assignment: conditions under which self test should occur]] to demonstrate the correct operation of [assignment: functions and/or mechanisms].

7 Security Requirements (ASE_REQ)

For this section the PP [1] section 6 can be applied completely.

7.1 TOE Security Functional Requirements

The security functional requirements (SFR) for the TOE are defined and described in the PP [1] section 6.1 and in the following description.

The Table 15 provides an overview of the functional security requirements of the TOE, defined in the in PP [1] section 6.1. In the last column it is marked if the requirement is refined. The refinements are also valid for this ST.

Table 14: Security functional requirements defined in PP [1]

Security Functional Requirement	Refined in PP [1]
FRU_FLT.2 "Limited fault tolerance"	Yes
FPT_FLS.1 "Failure with preservation of secure state"	Yes
FMT_LIM.1 "Limited capabilities"	No
FMT_LIM.2 "Limited availability"	No
FAU_SAS.1 "Audit storage"	No
FPT_PHP.3 "Resistance to physical attack"	Yes
FDP_ITT.1 "Basic internal transfer protection"	Yes
FPT_ITT.1 "Basic internal TSF data transfer protection"	Yes
FDP_IFC.1 "Subset information flow control"	No
FCS_RNG.1 "Quality metric for random numbers"	No

The Table 16 provides an overview about the augmented security functional requirements, which are added additional to the TOE and defined in this ST. All requirements are taken from Common Criteria Part 2 [3], with the exception of the requirement FPT_TST.2, which is defined in this ST completely.

Table 15: Augmented security functional requirements

Security Functional Requirement	
FPT_TST.2	“Subset TOE security testing“
FDP_ACC.1	“Subset access control“
FDP_ACF.1	“Security attribute based access control“
FMT_MSA.1	“Management of security attributes“
FMT_MSA.3	“Static attribute initialisation“
FMT_SMF.1	“Specification of Management functions“
FCS_COP.1	“Cryptographic support“
FCS_CKM.1	“Cryptographic key management“
FDP_SDI.1	“Stored data integrity monitoring“
FDP_SDI.2	“Stored data integrity monitoring and action“

All assignments and selections of the security functional requirements of the TOE are done in PP [1] and in the following description.

The above marked extended components FMT_LIM.1 and FMT_LIM.2 are introduced in PP [1] to define the IT security functional requirements of the TOE as an additional family (FMT_LIM) of the Class FMT (Security Management). This family describes the functional requirements for the Test Features of the TOE. The new functional requirements were defined in the class FMT because this class addresses the management of functions of the TSF.

The additional component FAU.SAS is introduced to define the security functional requirements of the TOE of the Class FAU (Security Audit). This family describes the functional requirements for the storage of audit data and is described in the next chapter.

The requirement FPT_TST.2 is the subset of TOE testing and originated in [3]. This requirement is given as the correct operation of the security functions is essential. The TOE provides mechanisms to cover this requirement by the smartcard embedded software and/or by the TOE itself.

7.1.1 Extended Components FCS_RNG.1 and FAU_SAS.1

7.1.1.1 FCS_RNG

To define the IT security functional requirements of the TOE an additional family (FCS_RNG) of the Class FCS (cryptographic support) is defined here. This family describes the functional requirements for random number generation used for cryptographic purposes.

FCS_RNG.1 Random Number Generation

Hierarchical to: No other components

Dependencies: No dependencies

FCS_RNG.1	Generation of random numbers requires that random numbers meet a defined quality metric.
FCS_RNG.1.1	The TSF shall provide a physical random number generator that implements total failure test of the random source <i>and a continuous RNG test according to: National Institute of Standards and Technology, Security Requirements for Cryptographic Modules, Federal Information Processing Standards Publication (FIPS) 140-2, 1999.</i>
FCS_RNG.1.2	The TSF shall provide random numbers that meet <i>the functionality class P2 with SOF-high of [6].</i>

7.1.1.2 FAU_SAS

To define the security functional requirements of the TOE an additional family (FAU_SAS) of the Class FAU (Security Audit) is defined here. This family describes the functional requirements for the storage of audit data. It has a more general approach than FAU_GEN, because it does not necessarily require the data to be generated by the TOE itself and because it does not give specific details of the content of the audit records.

The TOE shall meet the requirement “Audit storage (FAU_SAS.1)” as specified below (Common Criteria Part 2 extended).

FAU_SAS.1	Audit Storage
Hierarchical to:	No dependencies
Dependencies:	No dependencies.
FAU_SAS.1.1	The TSF shall provide the test process <i>before TOE Delivery</i> with the capability to store <i>the Initialization Data and/or Pre-personalization Data and/or supplements of the Security IC Embedded Software</i> in the <i>not changeable configuration page area and non-volatile memory.</i>

7.1.2 Subset of TOE testing

The security is strongly dependent on the correct operation of the security functions. Therefore, the TOE shall support that particular security functions or mechanisms are tested in the operational phase (Phase 7). The tests can be initiated by the Smartcard Embedded Software and/or by the TOE.

The TOE shall meet the requirement “Subset TOE testing (FPT_TST.2)” as specified below (Common Criteria Part 2 extended).

FPT_TST.2	Subset TOE testing
Hierarchical to:	No other components.
Dependencies:	No dependencies.
FPT_TST.2.1	The TSF shall run a suite of self tests <i>at the request of the authorised user</i> to demonstrate the correct operation of the <i>alarm lines and/or following environmental sensor mechanisms:</i>

- *The details can be obtained in the confidential Security Target [16].*

7.1.3 Memory access control

Usage of multiple applications in one Smartcard often requires code and data separation in order to prevent that one application can access code and/or data of another application. For this reason the TOE provides Area based Memory Access Control. The underlying memory management unit (MMU) is documented in section 4 of the [7].

The security service being provided is described in the Security Function Policy (SFP) **Memory Access Control Policy**. The security functional requirement “**Subset access control (FDP_ACC.1)**” requires that this policy is in place and defines the scope where it applies. The security functional requirement “**Security attribute based access control (FDP_ACF.1)**” defines security attribute usage and characteristics of policies. It describes the rules for the function that implements the Security Function Policy (SFP) as identified in FDP_ACC.1. The decision whether an access is permitted or not is taken based upon attributes allocated to the software. The Smartcard Embedded Software defines the attributes and memory areas. The corresponding permission control information is evaluated “on-the-fly” by the hardware so that access is granted/effective or denied/inoperable.

The security functional requirement “**Static attribute initialisation (FMT_MSA.3)**” ensures that the default values of security attributes are appropriately either permissive or restrictive in nature. Alternative values can be specified by any subject provided that the **Memory Access Control Policy** allows that. This is described by the security functional requirement “**Management of security attributes (FMT_MSA.1)**”. The attributes are determined during TOE manufacturing (FMT_MSA.3) or set at run-time (FMT_MSA.1).

From TOE’s point of view the different roles in the Smartcard Embedded Software can be distinguished according to the memory based access control. However the definition of the roles belongs to the user software.

The following Security Function Policy (SFP) **Memory Access Control Policy** is defined for the requirement “Security attribute based access control (FDP_ACF.1)”:

Memory Access Control Policy

The TOE shall control read, write, delete and execute accesses of software running at the privilege levels as defined below. Any access is controlled, regardless whether the access is on code or data or a jump on any other privilege level outside the current one.

The memory model provides distinct, independent privilege levels separated from each other in the virtual address space. The access rights are controlled by the MMU and related to the privilege level assigned.

The TOE shall meet the requirement “Subset access control (FDP_ACC.1)” as specified below.

FDP_ACC.1	Subset access control
Hierarchical to:	No other components.
Dependencies:	FDP_ACF.1 Security attribute based access control
FDP_ACC.1.1	The TSF shall enforce the <i>Memory Access Control Policy</i> on <i>all subjects (software running at the defined and assigned privilege levels), all objects (data including code stored in memories) and all the operations defined in the Memory Access Control Policy, i.e. privilege levels.</i>

The TOE shall meet the requirement “Security attribute based access control (FDP_ACF.1)” as specified below.

FDP_ACF.1	Security attribute based access control
Hierarchical to:	No other components.
Dependencies:	FDP_ACC.1 Subset access control FMT_MSA.3 Static attribute initialisation
FDP_ACF.1.1	<p>The TSF shall enforce the <i>Memory Access Control Policy</i> to objects based on the following:</p> <p><i>Subject:</i></p> <ul style="list-style-type: none"> - <i>software running at the IFX, OS1 and OS2 privilege levels required to securely operate the chip. This includes also privilege levels running interrupt routines.</i> - <i>software running at the privilege levels containing the application software</i> <p><i>Object:</i></p> <ul style="list-style-type: none"> - <i>data including code stored in memories</i> <p><i>Attributes:</i></p> <ul style="list-style-type: none"> - <i>the memory area where the access is performed to and/or</i> - <i>the operation to be performed.</i>
FDP_ACF.1.2	The TSF shall enforce the following rules to determine if an operation among controlled subjects and controlled objects is allowed: <i>evaluate the corresponding permission control information of the relevant memory range before, during or after the access so that accesses to be denied can not be utilised by the subject attempting to perform the operation.</i>
FDP_ACF.1.3	The TSF shall explicitly authorize access of subjects to objects based on the following additional rules: <i>none.</i>
FDP_ACF.1.4	The TSF shall explicitly deny access of subjects to objects based on the following additional rules: <i>none.</i>

The TOE shall meet the requirement “Static attribute initialisation (FMT_MSA.3)” as specified below.

FMT_MSA.3	Static attribute initialisation
Hierarchical to:	No other components.
Dependencies:	FMT_MSA.1 Management of security attributes FMT_SMR.1 Security roles
FMT_MSA.3.1	The TSF shall enforce the <i>Memory Access Control Policy</i> to provide <i>well defined</i> ¹ default values for security attributes that are used to enforce the SFP.

¹ The static definition of the access rules is documented in [7]

FMT_MSA.3.2 The TSF shall allow *any subject, provided that the Memory Access Control Policy is enforced and the necessary access is therefore allowed¹*, to specify alternative initial values to override the default values when an object or information is created.

The TOE shall meet the requirement “Management of security attributes (FMT_MSA.1)” as specified below:

FMT_MSA.1 Management of security attributes

Hierarchical to: No other components.

Dependencies: [FDP_ACC.1 Subset access control or
FDP_IFC.1 Subset information flow control]
FMT_SMF.1 Specification of management functions
FMT_SMR.1 Security roles

FMT_MSA.1.1 The TSF shall enforce the *Memory Access Control Policy* to restrict the ability to *change default, modify or delete* the security attributes *permission control information to the software running on the privilege levels*.

The TOE shall meet the requirement “Specification of management functions (FMT_SMF.1)” as specified below:

FMT_SMF.1 Specification of management functions

Hierarchical to: No other components

Dependencies: No dependencies

FMT_SMF.1.1 The TSF shall be capable of performing the following security management functions: *access the configuration registers of the MMU*.

7.1.4 Support of Cipher Schemes

The following additional specific security functionality is implemented in the TOE:

FCS_COP.1 Cryptographic operation requires a cryptographic operation to be performed in accordance with a specified algorithm and with a cryptographic key of specified sizes. The specified algorithm and cryptographic key sizes can be based on an assigned standard; dependencies are discussed in Section 7.3.1.1.

The following additional specific security functionality is implemented in the TOE:

- Advanced Encryption Standard (AES)
- Triple Data Encryption Standard (3DES)
- Elliptic Curve Cryptography (EC)

¹ The Smartcard Embedded Software is intended to set the memory access control policy

- Rivest-Shamir-Adleman (RSA)¹
- Secure Hash Algorithm (SHA-2)

Note that the additional function of the EC library, providing the primitive elliptic curve operations, does not add specific security functionality.

7.1.4.1 Preface regarding Security Level related to Cryptography

The strength of the cryptographic algorithms was not rated in the course of the product certification (see BSIG Section 9, Para.4, Clause 2). But cryptographic functionalities with a security level of 80 bits or lower can no longer be regarded as secure against attacks with high attack potential without considering the application context. Therefore for these functions it shall be checked whether the related cryptographic operations are appropriate for the intended system. Some further hints and guidelines can be derived from the “Technische Richtlinie BSI TR-02102”, www.bsi.bund.de. The cryptographic functionalities 2-key Triple-DES, RSA 1024 provided by the TOE achieves a security level of maximum 80 Bits (in general context).

7.1.4.2 Triple-DES Operation

The DES Operation of the TOE shall meet the requirement “Cryptographic operation (FCS_COP.1)” as specified below.

FCS_COP.1/DES	Cryptographic operation
Hierarchical to:	No other components.
Dependencies:	[FDP_ITC.1 Import of user data without security attributes, or FDP_ITC.2 Import of user data with security attributes, or FCS_CKM.1 Cryptographic key management] FCS_CKM.4 Cryptographic key destruction
FCS_COP.1.1/DES	The TSF shall perform <i>encryption and decryption</i> in accordance with a specified cryptographic algorithm <i>Triple Data Encryption Standard (3DES)</i> , with cryptographic key sizes of <i>2 x 56 bit or 3 x 56 bit</i> , that meet the following <i>standards</i> : <i>National Institute of Standards and Technology (NIST), Technology Administration, U.S. Department of Data Encryption Standard (DES), NIST Special Publication 800-67, Version 1.1</i>

Note 6:

The TOE implements various block cipher modes of which the user can choose. More details are given in the confidential Security Target [16].

This TOE can come with both crypto co-processors accessible, or with a blocked SCP or with a blocked Crypto2304T, or with both crypto co-processors blocked. The blocking depends on the customer demands prior to the production of the hardware. In case the SCP is blocked, no AES and 3DES computation supported by hardware is possible. In case the Crypto2304T is blocked, no RSA and EC computation supported by hardware is possible. In case of a blocked Crypto2304T the optionally delivered cryptographic and the supporting Toolbox and Base Library can not be used in that TOE product. The use of the SHA-2 library is also possible with both crypto coprocessors blocked. No accessibility of the deselected cryptographic co-processors is without impact on any other security policy of the TOE; it is exactly equivalent to the situation where the user decides just

¹ For the case the TOE comes without RSA and/or EC library, the TOE provides basic HW-related routines for RSA and/or EC calculations. For a secure library implementation the user has to implement additional countermeasures himself.

not to use the cryptographic co-processors.
Please consider also the statement of chapter 7.1.4.1.

End of note.

7.1.4.3 AES Operation

The AES Operation of the TOE shall meet the requirement “Cryptographic operation (FCS_COP.1)” as specified below.

FCS_COP.1/AES	Cryptographic operation
Hierarchical to:	No other components.
Dependencies:	[FDP_ITC.1 Import of user data without security attributes, or FDP_ITC.2 Import of user data with security attributes, or FCS_CKM.1 Cryptographic key generation] FCS_CKM.4 Cryptographic key destruction
FCS_COP.1.1/AES	The TSF shall perform <i>encryption and decryption</i> in accordance with a specified cryptographic algorithm <i>Advanced Encryption Standard (AES)</i> and cryptographic key sizes of <i>128 bit or 192 bit or 256 bit</i> that meet the following standards: <i>U.S. Department of Commerce, National Institute of Standards and Technology, Information Technology Laboratory (ITL), Advanced Encryption Standard (AES), FIPS PUB 197</i>

Note 7:

This TOE can come with both crypto co-processors accessible, or with a blocked SCP or with a blocked Crypto2304T, or with both crypto co-processors blocked. The blocking depends on the customer demands prior to the production of the hardware. In case the SCP is blocked, no AES and 3DES computation supported by hardware is possible. In case the Crypto2304T is blocked, no RSA and EC computation supported by hardware is possible. In case of a blocked Crypto2304T the optionally delivered cryptographic and the supporting Toolbox and Base Library can not be used in that TOE product. The use of the SHA-2 library is also possible with both crypto coprocessors blocked. No accessibility of the deselected cryptographic co-processors is without impact on any other security policy of the TOE; it is exactly equivalent to the situation where the user decides just not to use the cryptographic co-processors.

Please consider also the statement of chapter 7.1.4.1.

End of note.

7.1.4.4 Rivest-Shamir-Adleman (RSA) operation

The Modular Arithmetic Operation of the TOE shall meet the requirement “Cryptographic operation (FCS_COP.1)” as specified below.

FCS_COP.1/RSA	Cryptographic operation
Hierarchical to:	No other components.
Dependencies:	[FDP_ITC.1 Import of user data without security attributes, or FDP_ITC.2 Import of user data with security attributes, or FCS_CKM.1 Cryptographic key generation] FCS_CKM.4 Cryptographic key destruction

FCS_COP.1.1/RSA The TSF shall perform *encryption and decryption* in accordance with a specified cryptographic algorithm *Rivest-Shamir-Adleman (RSA)* and cryptographic key sizes *1024 - 4096 bits* that meet the following standards

Encryption:

According to section 5.1.1 RSAEP in PKCS v2.1 RFC3447, without 5.1.1.1.

Decryption (with or without CRT):

According to section 5.1.2 RSADP in PKCS v2.1 RFC3447 for $u = 2$, i.e., without any (r_i, d_i, t_i) , $i > 2$, therefore without 5.1.2.2.b (ii)&(v), without 5.1.2.1.5.1.2.2.a, only supported up to $n < 2^{2048}$

Signature Generation (with or without CRT)::

According to section 5.2.1 RSASP1 in PKCS v2.1 RFC3447 for $u = 2$, i.e., without any (r_i, d_i, t_i) , $i > 2$, therefore without 5.2.1.2.b (ii)&(v), without 5.2.1.1.5.2.1.2.a, only supported up to $n < 2^{2048}$

Signature Verification:

According to section 5.2.2 RSAVP1 in PKCS v2.1 RFC3447, without 5.2.2.1.

Please consider also the statement of chapter 7.1.4.1.

7.1.4.5 Rivest-Shamir-Adleman (RSA) key generation

The key generation for the RSA shall meet the requirement “Cryptographic key generation (FCS_CKM.1)”

FCS_CKM.1/RSA Cryptographic key generation

Hierarchical to: No other components.

Dependencies: FCS_CKM.2 Cryptographic key distribution, or
FCS_COP.1 Cryptographic operation]
FCS_CKM.4 Cryptographic key destruction
FMT_MSA.2 Secure security attributes

FCS_CKM.1.1/RSA The TSF shall generate cryptographic keys in accordance with a specified cryptographic key generation algorithm *rsagen1 (PKCS v2.1 RFC3447)* and specified cryptographic key sizes of *1024 – 4096 bits* that meet the following *standard*:

According to section 3.2(2) in PKCS v2.1 RFC3447, for $u=2$, i.e., without any (r_i, d_i, t_i) , $i > 2$. For $p \times q < 2^{2048}$ additionally according to section 3.2(1).

Note 8:

For easy integration of RSA functions into the user’s operating system and/or application, the library contains single cryptographic functions respectively primitives which are compliant to the standard. The primitives are referenced above. Therefore, the library supports the user to develop an

application representing the standard if required.
Please consider also the statement of chapter 7.1.4.1.
End of note.

Note 9:

The TOE can be delivered with or without the RSA library. If the TOE comes with, automatically the Base Library is part of the shipment. In the case of coming without the RSA library the TOE does not provide the Additional Specific Security Functionality Rivest-Shamir-Adleman Cryptography (RSA) realized with the security functional requirements FCS_COP.1/RSA and FCS_CKM.1/RSA. In case of a blocked Crypto2304T the optionally delivered cryptographic and the supporting Toolbox and Base Library can not be used in that TOE product.

End of note.

7.1.4.6 Generally with regard to Elliptic Curves

The EC library is delivered as object code and in this way integrated in the user software. The certification covers the standard NIST [14] and Brainpool [15] Elliptic Curves with key lengths of 192 to 521 Bits, due to national AIS32 regulations by the BSI. Note that numerous other curve types are also secure in terms of side channel attacks on this TOE, which the user can optionally add in the composition certification process.

7.1.4.7 Elliptic Curve DSA (ECDSA) operation

The Modular Arithmetic Operation of the TOE shall meet the requirement “Cryptographic operation (FCS_COP.1)” as specified below.

FCS_COP.1/ECDSA Cryptographic operation

Hierarchical to: No other components.

Dependencies: [FDP_ITC.1 Import of user data without security attributes, or
FDP_ITC.2 Import of user data with security attributes, or
FCS_CKM.1 Cryptographic key generation]
FCS_CKM.4 Cryptographic key destruction

FCS_COP.1.1/ECDSA

The TSF shall perform *signature generation and signature verification* in accordance with a specified cryptographic algorithm *ECDSA* and cryptographic key sizes *192 - 521 bits* that meet the following *standard*:

Signature Generation:

1. According to section 7.3 in ANSI X9.62 - 2005

Not implemented is step d) and e) thereof.

The output of step e) has to be provided as input to our function by the caller.

Deviation of step c) and f):

The jumps to step a) were substituted by a return of the function with an error code, the jumps are emulated by another call to our function.

2. According to sections 6.2 (6.2.2. + 6.2.3) in ISO/IEC 15946-2:2002

Not implemented is section 6.2.1:

The output of 5.4.2 has to be provided by the caller as input to the function.

Signature Verification:

1. According to section 7.4.1 in ANSI X9.62–2005
*Not implemented is step b) and c) thereof.
 The output of step c) has to be provided as input to our function by the caller.
 Deviation of step d):
 Beside noted calculation, our algorithm adds a random multiple of BasepointerOrder n to the calculated values $u1$ and $u2$.*
2. According to sections 6.4 (6.4.1. + 6.4.3 + 6.4.4) in ISO/IEC 15946-2:2002
*Not implemented is section 6.4.2:
 The output of 5.4.2 has to be provided by the caller as input to the function.*

Note 10:

For easy integration of EC functions into the user's operating system and/or application, the library contains single cryptographic functions respectively primitives which are compliant to the standard. The primitives are referenced above. Therefore, the library supports the user to develop an application representing the standard if required.
 End of note.

7.1.4.8 Elliptic Curve (EC) key generation

The key generation for the EC shall meet the requirement "Cryptographic key generation (FCS_CKM.1)"

FCS_CKM.1/EC Cryptographic key generation

Hierarchical to: No other components.

Dependencies: FCS_CKM.2 Cryptographic key distribution, or
 FCS_COP.1 Cryptographic operation]
 FCS_CKM.4 Cryptographic key destruction

FCS_CKM.1.1/EC The TSF shall generate cryptographic keys in accordance with a specified cryptographic key generation algorithm *Elliptic Curve EC specified in ANSI X9.62-2005 and ISO/IEC 15946-1:2002* and specified cryptographic key sizes 192 - 521 bits that meet the following standard:

ECDSA Key Generation:

1. According to the appendix A4.3 in ANSI X9.62-2005
the cofactor h is not supported.
2. According to section 6.1 (not 6.1.1) in ISO/IEC 15946-1:2002

Note 11:

For easy integration of EC functions into the user's operating system and/or application, the library contains single cryptographic functions respectively primitives which are compliant to the standard. The primitives are referenced above. Therefore, the library supports the user to develop an application representing the standard if required.
 End of note.

7.1.4.9 Elliptic Curve Diffie-Hellman (ECDH) key agreement

The Modular Arithmetic Operation of the TOE shall meet the requirement “Cryptographic operation (FCS_COP.1)” as specified below.

FCS_COP.1/ECDH Cryptographic operation

Hierarchical to: No other components.

Dependencies: [FDP_ITC.1 Import of user data without security attributes, or
FDP_ITC.2 Import of user data with security attributes, or
FCS_CKM.1 Cryptographic key generation]
FCS_CKM.4 Cryptographic key destruction

FCS_COP.1.1/ECDH

The TSF shall perform *elliptic curve Diffie-Hellman key agreement* in accordance with a specified cryptographic algorithm *ECDH* and cryptographic key sizes *192 - 521 bits* that meet the following *standard*:

- 1. According to section 5.4.1 in ANSI X9.63-2001
Unlike section 5.4.1.3 our, implementation not only returns the x-coordinate of the shared secret, but rather the x-coordinate and y-coordinate.*
- 2. According to sections 8.4.2.1, 8.4.2.2, 8.4.2.3, and 8.4.2.4 in ISO/IEC 15946-3:2002:
The function enables the operations described in the four sections.*

Note 12:

The certification covers the standard NIST [14] and Brainpool [15] Elliptic Curves with key lengths of 192 to 521 Bits, due to national AIS32 regulations by the BSI. Note that numerous other side channel attack resistant curve types exist, which the user optionally can add in the composition certification process.

End of note

Note 13:

For easy integration of EC functions into the user’s operating system and/or application, the library contains single cryptographic functions respectively primitives which are compliant to the standard. The primitives are referenced above. Therefore, the library supports the user to develop an application representing the standard if required.

End of note.

Note 14:

The TOE can be delivered with or without the EC library. If the TOE comes with, automatically the Base Library is part of the shipment. In the case the TOE comes without, it does not provide the Additional Specific Security Functionality Elliptic Curve Cryptography realized with the security functional requirements FCS_COP.1/ECSA, FCS_COP.1/ECDH and FCS_CKM.1/EC. In case of a blocked Crypto2304T, the RSA and EC cryptographic library can not be used. In case of a blocked Crypto2304T the optionally delivered cryptographic RSA and EC, as well as the supporting Toolbox and Base Library can not be used in that TOE product.

End of note.

Note 15:

The EC primitives allow the selection of various curves. The selection of the curves depends to the user.

End of note.

7.1.4.10 SHA-2 Operation

The SHA-2 Operation of the TOE shall meet the requirement “Cryptographic operation (FCS_COP.1)” as specified below.

FCS_COP.1/SHA Cryptographic operation

Hierarchical to: No other components.

Dependencies: [FDP_ITC.1 Import of user data without security attributes, or
FDP_ITC.2 Import of user data with security attributes, or
FCS_CKM.1 Cryptographic key generation]
FCS_CKM.4 Cryptographic key destruction

FCS_COP.1/SHA The TSF shall perform *hash-value calculation of user chosen data* in accordance with a specified cryptographic algorithm *SHA-2* and with cryptographic key sizes of *none* that meet the following *standards*:

*U.S. Department of Commerce / National Bureau of Standards
Secure Hash Algorithm, FIPS PUB 180-3, 2008-October, section 6.2
SHA-256 and section 6.4 SHA-512.*

Note that the SHA-2 cryptographic operation is a keyless operation.

In case of a blocked Crypto2304T no cryptographic libraries are delivered.

Note 16:

The TOE can be delivered without the SHA-2 library. In this case the TOE does not provide the Additional Specific Security Functionality SHA-2 library, realised with the security functional requirements FCS_COP.1/SHA.

End of note.

Note 17:

The secure hash-algorithm SHA-2 is intended to be used for signature generation, verification and generic data integrity checks. The use for keyed hash operations like HMAC or similar security critical operations involving keys, is not subject of this TOE and requires specific security improvements and DPA analysis including the operating system, which is not part of this TOE.

7.1.5 Data Integrity

The TOE shall meet the requirement “Stored data integrity monitoring (FDP_SDI.1)” as specified below:

FDP_SDI.1 Stored data integrity monitoring

Hierarchical to: No other components

Dependencies: No dependencies

FDP_SDI.1.1 The TSF shall monitor user data stored in containers controlled by the TSF for *inconsistencies between stored data and corresponding EDC* on all objects, based on the following attributes: *EDC value for the RAM, ROM and SOLID FLASH™*.

The TOE shall meet the requirement “Stored data integrity monitoring and action (FDP_SDI.2)” as specified below:

FDP_SDI.2	Stored data integrity monitoring and action
Hierarchical to:	FDP_SDI.1 stored data integrity monitoring
Dependencies:	No dependencies
FDP_SDI.2.1	The TSF shall monitor user data stored in containers controlled by the TSF for <i>data integrity and one- and/or more-bit-errors</i> on all objects, based on the following attributes: <i>corresponding EDC value for RAM, ROM and SOLID FLASH™ and error correction ECC for the SOLID FLASH™.</i>
FDP_SDI.2.2	Upon detection of a data integrity error, the TSF shall <i>correct 1 bit errors in the SOLID FLASH™ automatically and inform the user about more bit errors.</i>

7.2 TOE Security Assurance Requirements

The evaluation assurance level is EAL 5 augmented with ALC_DVS.2 and AVA_VAN.5. In the following table, the security assurance requirements are given. The augmentation of the assurance components compared to the Protection Profile [1] is expressed with bold letters.

Table 16: Assurance components

Aspect	Acronym	Description	Refinement
Development	ADV_ARC.1	Security Architecture Description	In PP [1]
	ADV_FSP.5	Complete semi-formal functional specification with additional error information	in ST
	ADV_IMP.1	Implementation representation of the TSF	in PP [1]
	ADV_INT.2	Well-structured internals	
	ADV_TDS.4	Semi-formal modular design	
Guidance Documents	AGD_OPE.1	Operational user guidance	in PP [1]
	AGD_PRE.1	Preparative procedures	in PP [1]
Life-Cycle Support	ALC_CMC.4	Production support, acceptance procedures and automation	in PP [1]
	ALC_CMS.5	Development tools CM coverage	in ST
	ALC_DEL.1	Delivery procedures	in PP [1]
	ALC_DVS.2	Identification of security measures	in PP [1]
	ALC_LCD.1	Developer defined life-cycle model	
	ALC_TAT.2	Compliance with implementation standards	
Security Target	ASE_CCL.1	Conformance claims	

Aspect	Acronym	Description	Refinement
Evaluation	ASE_ECD.1	Extended components definition	
	ASE_INT.1	ST introduction	
	ASE_OBJ.2	Security objectives	
	ASE_REQ.2	Derived security requirements	
	ASE_SPD.1	Security problem definition	
	ASE_TSS.1	TOE summary specification	
Tests	ATE_COV.2	Analysis of coverage	in PP [1]
	ATE_DPT.3	Testing: modular design	
	ATE_FUN.1	Functional testing	
	ATE_IND.2	Independent testing - sample	
Vulnerability Assessment	AVA_VAN.5	Advanced methodical vulnerability testing	in PP [1]

7.2.1 Refinements

Some refinements are taken unchanged from the PP [1]. In some cases a clarification is necessary. In Table 16 an overview is given where the refinement is done.

Two refinements from the PP [1] have to be discussed here in the Security Target, as the assurance level is increased.

7.2.1.1 Life cycle support (ALC_CMS)

The refinement from the PP [1] can be applied even at the chosen assurance level EAL 5 augmented with ALC_CMS.5. The assurance package ALC_CMS.4 is extended to ALC_CMS.5 with aspects regarding the configuration control system for the TOE. The refinement is not touched.

7.2.1.2 Functional Specification (ADV_FSP)

The refinement from the PP [1] can be applied even at the chosen assurance level EAL 5 augmented with ADV_FSP.5. The assurance package ADV_FSP.4 is extended to ADV_FSP.5 with aspects regarding the descriptive level. The level is increased from informal to semi-formal with informal description. The refinement is not touched from this measure.

For details of the refinement see PP [1].

7.3 Security Requirements Rationale

7.3.1 Rationale for the Security Functional Requirements

The security functional requirements rationale of the TOE are defined and described in PP [1] section 6.3 for the following security functional requirements: FDP_ITT.1, FDP_IFC.1, FPT_ITT.1, FPT_PHP.3, FPT_FLS.1, FRU_FLT.2, FMT_LIM.1, FMT_LIM.2, FCS_RNG.1, and FAU_SAS.1.

The security functional requirements FPT_TST.2, FDP_ACC.1, FDP_ACF.1, FMT_MSA.1, FMT_MSA.3, FMT_SMF.1, FCS_COP.1, FCS_CKM.1, FDP_SDI.1 and FDP_SDI.2 are defined in the following description:

Table 17: Rational for additional SFR in the ST

Objective	TOE Security Functional Requirements
O.Add-Functions	- FCS_COP.1/DES „Cryptographic operation“ - FCS_COP.1/AES „Cryptographic operation“ - FCS_COP.1/SHA „Cryptographic operation“ - FCS_COP.1/RSA „Cryptographic operation“ - FCS_COP.1/ECDSA „Cryptographic operation“ - FCS_COP.1/ECDH „Cryptographic operation“ - FCS_CKM.1/RSA „Cryptographic key generation “ - FCS_CKM.1/EC „Cryptographic key generation“
O.Phys-Manipulation	- FPT_TST.2 „ Subset TOE security testing “
O.Mem-Access	- FDP_ACC.1 “Subset access control” - FDP_ACF.1 “Security attribute based access control” - FMT_MSA.3 “Static attribute initialisation” - FMT_MSA.1 “Management of security attributes” - FMT_SMF.1 “Specification of Management Functions”
O.Malfunction	- FDP_SDI.1 „Stored data integrity monitoring“ - FDP_SDI.2 „Stored data integrity monitoring and action“

The table above gives an overview, how the security functional requirements are combined to meet the security objectives. The detailed justification is given in the following:

The justification related to the security objective “Additional Specific Security Functionality (O.Add-Functions)” is as follows:

The security functional requirement(s) “Cryptographic operation (FCS_COP.1)” exactly requires those functions to be implemented which are demanded by O.Add-Functions. FCS_CKM.1/RSA supports the generation of RSA keys, the FCS_CKM.1/EC supports the generation of EC keys needed for this cryptographic operations. Therefore, FCS_COP.1/RSA, FCS_COP.1/ECDSA, FCS_COP.1/ECDH and FCS_CKM.1/RSA and FCS_CKM/EC are suitable to meet the security objective. The FCS_COP.1/SHA is a keyless algorithm and has no dependencies to FCS_CKM.1.

The use of the supporting libraries Toolbox and Base has no impact on any security functional requirement nor does the use generate additional requirements.

Nevertheless, the developer of the Smartcard Embedded Software must ensure that the additional functions are used as specified and that the User Data processed by these functions are protected as defined for the application context. These issues are addressed by the specific security functional requirements:

- [FDP_ITC.1 Import of user data without security attributes or FDP_ITC.2 Import of user data with security attributes or FCS_CKM.1 Cryptographic key generation],
- FCS_CKM.4 Cryptographic key destruction,

All these requirements have to be fulfilled to support OE.Resp-Appl for FCS_COP.1/DES (3DES algorithm) and for FCS_COP.1/AES (AES algorithm). For the FCS_COP.1/RSA (RSA algorithm) and FCS_COP.1/ECDSA and FCS_COP.1/ECDH (both EC algorithms) the FCS_CKM.1/RSA and FCS_CKM.1/EC are optional, since they are fulfilled by the TOE or may be fulfilled by the environment as the user can generate keys externally additionally.

The security functional requirements required to meet the security objectives O.Leak-Inherent, O.Phys-Probing, O.Malfunction, O.Phys-Manipulation and O.Leak-Forced define how to implement the specific security functionality. However, key-dependent functions could be implemented in the Smartcard Embedded Software.

The usage of cryptographic algorithms requires the use of appropriate keys. Otherwise these cryptographic functions do not provide security. The keys have to be unique with a very high probability, and must have a certain cryptographic strength etc. In case of a key import into the TOE (which is usually after TOE delivery) it has to be ensured that quality and confidentiality are maintained. Keys for 3DES and AES are provided by the environment. Keys for RSA and EC algorithms can be provided either by the TOE or the environment.

In this ST the objectives for the environment OE.Plat-Appl and OE.Resp-Appl have been clarified. The Smartcard Embedded Software defines the use of the cryptographic functions FCS_COP.1 provided by the TOE. The requirements for the environment FDP_ITC.1, FDP_ITC.2, FCS_CKM.1 and FCS_CKM.4 support an appropriate key management. These security requirements are suitable to meet OE.Resp-Appl.

The justification of the security objective and the additional requirements (both for the TOE and its environment) show that they do not contradict to the rationale already given in the Protection Profile for the assumptions, policy and threats defined there.

The security functional component Subset TOE security testing (FPT_TST.2) has been newly created (Common Criteria Part 2 extended). This component allows that particular parts of the security mechanisms and functions provided by the TOE can be tested after TOE Delivery. This security functional component is used instead of the functional component FPT_TST.1 from Common Criteria Part 2. For the user it is important to know which security functions or mechanisms can be tested. The functional component FPT_TST.1 does not mandate to explicitly specify the security functions being tested. In addition, FPT_TST.1 requires verification of the integrity of TSF data and stored TSF executable code which might violate the security policy.

The tested security enforcing functions are SF_DPM Device Phase Management, SF_CS Cryptographic Support and SF_PMA Protection against modifying attacks.

The security functional requirement FPT_TST.2 will detect attempts to conduct a physical manipulation on the monitoring functions of the TOE. The objective of FPT_TST.2 is O.Phys-Manipulation. The physical manipulation will be tried to overcome security enforcing functions.

The security functional requirement “Subset access control (FDP_ACC.1)” with the related Security Function Policy (SFP) “Memory Access Control Policy” exactly require the implementation of an area based memory access control as required by O.Mem-Access. The related TOE security functional requirements FDP_ACC.1, FDP_ACF.1, FMT_MSA.3, FMT_MSA.1 and FMT_SMF.1 cover this security objective. The implementation of these functional requirements is represented by the dedicated privilege level concept.

The justification of the security objective and the additional requirements show that they do not contradict to the rationale already given in the Protection Profile for the assumptions, policy and threats defined there. Moreover, these additional security functional requirements cover the requirements by [3] user data protection of chapter 11 which are not refined by the PP [1].

Nevertheless, the developer of the Smartcard Embedded Software must ensure that the additional functions are used as specified and that the User Data processed by these functions are protected as defined for the application context. The TOE only provides the tool to implement the policy defined in the context of the application.

The justification related to the security objective “Protection against Malfunction due to Environmental Stress (O.Malfunction)” is as follows:

The security functional requirement “Stored data integrity monitoring (FDP_SDI.1)” requires the implementation of an Error Detection (EDC) algorithm which detects integrity errors of the data stored in all memories. By this the malfunction of the TOE using corrupt data is prevented. Therefore FDP_SDI.1 is suitable to meet the security objective.

The security functional requirement “Stored data integrity monitoring and action (FDP_SDI.2)” requires the implementation of an integrity observation and correction which is implemented by the Error Detection (EDC) and Error Correction (ECC) measures. The EDC is present throughout all memories of the TOE while the ECC is realized in the SOLID FLASH™. These measures detect and inform about one and more bit errors. In case of the SOLID FLASH™ 1 bit errors of the data are corrected automatically. By the ECC mechanisms it is prevented that the TOE uses corrupt data. Therefore FDP_SDI.2 is suitable to meet the security objective.

7.3.1.1 Dependencies of Security Functional Requirements

The dependence of security functional requirements are defined and described in PP [1] section 6.3.2 for the following security functional requirements: FDP_ITT.1, FDP_IFC.1, FPT_ITT.1, FPT_PHP.3, FPT_FLS.1, FRU_FLT.2, FMT_LIM.1, FMT_LIM.2, FCS_RNG.1 and FAU_SAS.1.

The dependence of security functional requirements for the security functional requirements FPT_TST.2, FDP_ACC.1, FDP_ACF.1, FMT_MSA.1, FMT_MSA.3, FMT_SMF.1, FCS_COP.1, FCS_CKM.1, FDP_SDI.1 and FDP_SDI.2 are defined in the following description.

Table 18: Dependency for cryptographic operation requirement

Security Functional Requirement	Dependencies	Fulfilled by security requirements
FCS_COP.1/DES	FCS_CKM.1	Yes, see comment 3
	FDP_ITC.1 or FDP_ITC.2 (if not FCS_CKM.1) FCS_CKM.4	Yes, see comment 3
FCS_COP.1/AES	FCS_CKM.1	Yes, see comment 3
	FDP_ITC.1 or FDP_ITC.2 (if not FCS_CKM.1) FCS_CKM.4	Yes, see comment 3
FCS_COP.1/RSA	FCS_CKM.1	Yes, see comment 3
	FDP_ITC.1 or FDP_ITC.2 (if not FCS_CKM.1) FCS_CKM.4	Yes, see comment 3
FCS_CKM.1/RSA	FCS_CKM.2 or FCS_COP.1	Yes
	FCS_CKM.4	Yes, see comment 3
FCS_COP.1/ECDSA	FCS_CKM.1	Yes, see comment 3
	FDP_ITC.1 or FDP_ITC.2 (if not FCS_CKM.1) FCS_CKM.4	Yes, see comment 3
FCS_CKM.1/EC	FCS_CKM.2 or FCS_COP.1	Yes
	FCS_CKM.4	Yes, see comment 3
FCS_COP.1/ECDH	FCS_CKM.1	Yes, see comment 3
	FDP_ITC.1 or FDP_ITC.2 (if not FCS_CKM.1) FCS_CKM.4	Yes, see comment 3
FCS_COP.1/SHA	No dependencies, see comment 4	Yes, see comment 3
FPT_TST.2	No dependencies, see comment 1	No, see comment 1
FDP_ACC.1	FDP_ACF.1	Yes
FDP_ACF.1	FDP_ACC.1 FMT_MSA.3	Yes Yes
FMT_MSA.3	FMT_MSA.1 FMT_SMR.1	Yes Not required, see comment 2
FMT_MSA.1	FDP_ACC.1 or FDP_IFC.1 FMT_SMR.1 FMT_SMF.1	Yes see comment 2 Yes
FMT_SMF.1	None	N/A
FDP_SDI.1	None	N/A
FDP_SDI.2	None	N/A

Comment 1:

The TOE is already a platform representing the lowest level in a Smartcard. There is no lower or »underlying abstract machine« used by the TOE which can be tested. Therefore, the former dependency to FPT_AMT.1 is fulfilled without further and by that dispensable. CC in the Revision 3 considered this and dropped this dependency. The requirement FPT_TST.2 is satisfied.

End of comment.

Comment 2:

The dependency FMT_SMR.1 introduced by the two components FMT_MSA.1 and FMT_MSA.3 is considered to be satisfied because the access control specified for the intended TOE is not role-based but enforced for each subject. Therefore, there is no need to identify roles in form of a security functional requirement FMT_SMR.1.

End of comment.

Comment 3:

The security functional requirement “Cryptographic operation (FCS_COP.1)”, met by the, TOE has the following dependencies:

- [FDP_ITC.1 Import of user data without security attributes, or
- FDP_ITC.2 Import of user data with security attributes, or
- FCS_CKM.1 Cryptographic key generation]
- FCS_CKM.4 Cryptographic key destruction.

The security functional requirement “Cryptographic key management (FCS_CKM)” met by the TOE, has the following dependencies:

- [FCS_CKM.2 Cryptographic key distribution, or
- FCS_COP.1 Cryptographic operation]
- FCS_CKM.4 Cryptographic key destruction.

These requirements all address the appropriate management of cryptographic keys used by the specified cryptographic function and are not part of the PP [1]. Most requirements concerning key management shall be fulfilled by the environment since the Smartcard Embedded Software is designed for a specific application context and uses the cryptographic functions provided by the TOE.

For the security functional requirement FCS_COP.1/DES and FCS_COP.1/AES the respective dependencies FCS_CKM.1, FCS_CKM.4 and FDP_ITC.1 or FDP_ITC.2 have to be fulfilled by the environment. That mean, that the environment shall meet the requirements FCS_CKM.1 and FCS_CKM.4 as defined in [3], section 10.1 and shall meet the requirements FDP_ITC.1 or FDP_ITC.2 as defined in [3], section 11.7.

For the security functional requirement FCS_COP.1/RSA, FCS_COP.1/ECDSA and FCS_COP.1/ECDH the respective dependencies FCS_CKM.4 and FDP_ITC.1 or FDP_ITC.2 have to be fulfilled by the environment. That mean, that the environment shall meet the requirements FDP_ITC.1 or FDP_ITC.2 as defined in [3], section 11.7. The respective dependency FCS_CKM.1 has to be fulfilled by the TOE with the security functional requirement FCS_CKM.1/RSA (for FCS_COP.1/RSA) and FCS_CKM.1/EC (for FCS_COP.1/ECDSA and FCS_COP.1/ECDH) as defined in section 7.1.4. Additionally the requirement FCS_CKM.1 can be fulfilled by the environment as defined in [3], section 10.1.

For the security functional requirement FCS_CKM.1/RSA and FCS_CKM.1/EC the respective dependency FCS_COP.1 is fulfilled by the TOE. The environment covers the respective dependency FCS_CKM.4. That mean, that the environment shall meet the requirement FCS_CKM.4 as defined in [3], section 10.1.

The cryptographic libraries RSA, EC, SHA-2 and the Toolbox library are delivery options. If one of the libraries RSA, EC and Toolbox or combination hereof are delivered, the Base Lib is automatically part of it. Therefore the TOE may come with free combinations of or even without these libraries. In the case of coming without one or any combination of the cryptographic libraries RSA, EC and SHA-2, the TOE does not provide the Additional Specific Security Functionality Rivest-Shamir-Adleman Cryptography (RSA) and/or Elliptic Curve Cryptography (EC) and/or SHA-2. The Toolbox and Base Library are no cryptographic libraries and provide no additional specific security functionality.

In case of a blocked Crypto2304T no asymmetric cryptographic libraries are delivered. The SHA-2 library is computed in the CPUs. Therefore the IT environment has to fulfil the requirements of this chapter depending if the TOE comes with or without a/the library/ies. In case of a blocked Crypto2304T no cryptographic libraries are delivered.

End of comment.

Comment 4

The dependencies FCS_CKM.1 and FMT_CKM.4 are not required for the SHA-2 algorithm, because the SHA-2 algorithm is a keyless operation. So the environment is not obligated to meet certain requirements for key management.

End of comment.

7.3.2 Rationale of the Assurance Requirements

The chosen assurance level EAL5 and the augmentation with the requirements ALC_DVS.2 and AVA_VAN.5 were chosen in order to meet the assurance expectations explained in the following paragraphs. In Table 16 the different assurance levels are shown as well as the augmentations. The augmentations are in compliance with the Protection Profile.

An assurance level EAL5 with the augmentations ALC_DVS.2 and AVA_VAN.5 are required for this type of TOE since it is intended to defend against **highly sophisticated attacks** without protective environment. This evaluation assurance package was selected to permit a developer to gain maximum assurance from positive security engineering based on good commercial practices. In order to provide a meaningful level of assurance that the TOE provides an adequate level of defence against such attacks, the evaluators should have access to all information regarding the TOE including the TSF internals, the low level design and source code including the testing of the modular design. Additionally the mandatory technical document "Application of Attack Potential to Smartcards" [11] shall be taken as a basis for the vulnerability analysis of the TOE.

ALC_DVS.2 Sufficiency of security measures

Development security is concerned with physical, procedural, personnel and other technical measures that may be used in the development environment to protect the TOE.

In the particular case of a Security IC the TOE is developed and produced within a complex and distributed industrial process which must especially be protected. Details about the implementation, (e.g. from design, test and development tools as well as Initialization Data) may make such attacks easier. Therefore, in the case of a Security IC, maintaining the confidentiality of the design is very important.

This assurance component is a higher hierarchical component to EAL5 (which only requires ALC_DVS.1). ALC_DVS.2 has no dependencies.

AVA_VAN.5 Advanced methodical vulnerability analysis

Due to the intended use of the TOE, it must be shown to be highly resistant to penetration attacks. This assurance requirement is achieved by the AVA_VAN.5 component.

Independent vulnerability analysis is based on highly detailed technical information. The main intent of the evaluator analysis is to determine that the TOE is resistant to penetration attacks performed by an attacker possessing high attack potential.

AVA_VAN.5 has dependencies to ADV_ARC.1 "Security architecture description", ADV_FSP.2 "Security enforcing functional specification", ADV_TDS.3 "Basic modular design", ADV_IMP.1 "Implementation representation of the TSF", AGD_OPE.1 "Operational user guidance", and AGD_PRE.1 "Preparative procedures".

All these dependencies are satisfied by EAL5.

It has to be assumed that attackers with high attack potential try to attack these security controllers like smart cards used for digital signature applications or payment systems. Therefore, specifically AVA_VAN.5 was chosen in order to assure that even these attackers cannot successfully attack the TOE.

8 TOE Summary Specification (ASE_TSS)

The product overview is given in section 2.1. In the following the Security Features are described and the relation to the security functional requirements is shown.

The TOE is equipped with following Security Features to meet the security functional requirements:

SF_DPM	Device Phase Management
SF_PS	Protection against Snooping
SF_PMA	Protection against Modification Attacks
SF_PLA	Protection against Logical Attacks
SF_CSC	Cryptographic Support

The following description of the Security Features is a complete representation of the TSF.

8.1 SF_DPM: Device Phase Management

The life cycle of the TOE is split-up in several phases. Chip development and production (phase 2, 3, 4) and final use (phase 4-7) is a rough split-up from TOE point of view. These phases are implemented in the TOE as test mode (phase 3) and user mode (phase 4-7). In addition a chip identification mode exists which is active in all phases. The chip identification data (O.Identification) is stored in a in the not changeable configuration page area and non-volatile memory. In the same area further TOE configuration data is stored. In addition, user initialization data can be stored in the non-volatile memory during the production phase as well. During this first data programming, the TOE is still in the secure environment and in Test Mode. The covered security functional requirement is FAU_SAS.1 "Audit storage".

During start-up of the TOE the decision for one of the various operation modes is taken dependent on phase identifiers. The decision of accessing a certain mode is defined as phase entry protection. The phases follow also a defined and protected sequence. The sequence of the phases is protected by means of authentication.

The covered security functional requirements are FMT_LIM.1 and FMT_LIM.2.

During the production phase (phase 3 and 4) or after the delivery to the customer (phase 5 or phase 6), the TOE provides, after a successful authentication process, the possibility to download a user specific encryption key, user code and data into the empty (erased) SOLID FLASH™ flash memory area, as specified by the associated control information of the Flash Loader software. The integrity of the loaded data is checked with a signature process. The data to be loaded may be transferred optionally in encrypted form. After finishing the load operation, the Flash Loader can be permanently deactivated, so that no further load operation with the Flash Loader is possible. These procedures are defined as phase operation limitation.

The covered security functional requirement is FPT_LIM.2 "Limited availability".

During operation within a phase the accesses to memories are granted by the MMU controlled access rights and related privilege level.

The covered security functional requirements are FDP_ACC.1, FDP_ACF.1 and FMT_MSA.1.

In addition, during each start-up of the TOE the address ranges and access rights are initialized by the STS with predefined values. The covered security functional requirement is FMT_MSA.3.

The TOE clearly defines access rights and privilege levels in conjunction with the appropriate key management in dependency of the firmware or software to be executed. By this clearly defined

management functions are implemented, enforced by the MMU, and the covered security functional requirement is FMT_SMF.1.

During the testing phase in production within the secure environment the entire SOLID FLASH™ is deleted. The covered security functional requirement is FPT_PHP.3.

Each operation phase is protected by means of authentication and encryption. The covered security functional requirements are FDP_ITT.1 and FPT_ITT.1.

The **SF_DPM** “Device Phase Management” covers the security functional requirements FAU_SAS.1, FMT_LIM.1, FMT_LIM.2, FDP_ACC.1, FDP_ACF.1, FMT_MSA.1, FMT_MSA.3, FMT_SMF.1, FPT_PHP.3, FDP_ITT.1 and FPT_ITT.1.

8.2 SF_PS: Protection against Snooping

All contents of all memories of the TOE are encrypted on chip to protect against data analysis on stored data as well as on internally transmitted data. There is no plain data on the chip.

In addition the data transferred over the busses, the SFRs and the peripheral devices (CRC, RNG and Timer) are encrypted with different keys.

The memory content and bus encryption is done by the MED using a complex key management. This means that the SOLID FLASH™, RAM, CACHE and the bus are encrypted with module dedicated and different keys. Note that the ROM contains the firmware only and no user data.

Therefore, no data in plain are handled anywhere on the TOE and thus also the two CPUs compute entirely masked. The symmetric cryptographic co-processor is entirely masked as well.

The encryption covers the data processing policy and FDP_IFC.1 “Subset information flow control“. The covered security functional requirements are FPT_PHP.3, FDP_IFC.1, FPT_ITT.1 and FDP_ITT.1.

The user can define his own key for an SOLID FLASH™ area to protect his data. This user individually chosen key is then delivered by the operating system and included in the dynamic SOLID FLASH™ encryption. The user specified SOLID FLASH™ area is then encrypted with his key and another component. The encryption of the memories is performed by the MED with a proprietary cryptographic algorithm and with a complex key management providing protection against cryptographic analysis attacks. The few keys which have to be stored on the chip, for example the user chosen key and the chip specific ROM key, are protected against read out.

The covered security functional requirements are FPT_PHP.3, FDP_IFC.1, FPT_ITT.1, and FDP_ITT.1.

The CPU has no standard command set and discloses therefore no possibility for deeper analysis. The covered security functional requirement is FPT_PHP.3.

The entire design is kept in a non standard way to aggravate attacks using standard analysis methods to an almost not practical condition. A proprietary CPU with a non public bus protocol is implemented, which makes analysis very complicated and time consuming.

Important parts of the chip are especially designed to counter leakage or side channel attacks like DPA/SPA or EMA/DEMA. Therefore, even the physical data gaining is difficult to perform, since timing and current consumption is almost independent of the processed data, protected by a bunch of other protecting means.

In the design a number of components are automatically synthesized and mixed up to disguise their physical borders and to make an analysis more difficult.

A further protective design method implements special routing measures against probing. The covered security functional requirements are FPT_PHP.3, FPT_ITT.1 and FDP_ITT.1.

In addition to their protection during processing of code and data their storage in the SOLID FLASH™ is protected against side channel attacks too: Even if users operate with direct and static addressing for storing their secrets, the addresses are always translated to virtual addresses. But, only if the

address call is in the correct privilege level which is monitored by the MMU.
The covered security functional requirements are FPT_PHP.3, FPT_ITT.1 and FDP_ITT.1.

In contrast to the linear virtual address range, the physical SOLID FLASH™ pages are transparently and dynamically scrambled on every page modification. In addition, further measures scramble the SOLID FLASH™ even more. These measurements cause that the physical location of data is different from chip to chip. Even user software would always call the equal physical addresses. An observation of the clock is used to prevent the TOE from single stepping. This is tested by the user mode security life control UMSLC.

The covered security functional requirements are FPT_PHP.3 and FPT_FLS.1.

An induced error which can not be corrected will be recognized by the Integrity Guard and leads to an alarm. In case of security critical detections a security alarm and reset is generated. The covered security functional requirement is FPT_FLS.1.

The **SF_PS** “Protection against Snooping” covers the security functional requirements FPT_PHP.3, FDP_IFC.1, FPT_ITT.1, FDP_ITT.1 and FPT_FLS.1.

8.3 SF_PMA: Protection against Modifying Attacks

First of all we can say that all security mechanisms effective against snooping **SF_PS** apply also here since a reasonable modification of data is almost impossible on dynamically encrypted, masked, scrambled, transparently relocated, randomized and topologically protected hardware. Due to this the covered security functional requirements are FPT_PHP.3, FDP_IFC.1, FPT_ITT.1, FDP_ITT.1 and FPT_FLS.1.

The TOE is equipped with an error detection code (EDC) which covers the memory system of RAM, ROM and SOLID FLASH™ and includes also the MED, MMU and the bus system. Thus introduced failures are securely detected and in terms of single bit errors in the SOLID FLASH™ also automatically corrected (FDP_SDI.2).

In order to prevent accidental bit faults during production in the ROM, over the data stored in ROM an EDC value is calculated (FDP_SDI.1).

The covered security functional requirements are FRU_FLT.2, FPT_PHP.3, FDP_SDI.1 and FDP_SDI.2.

If a user tears the card resulting in a power off situation during an NVM programming operation or if other perturbation is applied, no data or content loss occurs and the TOE restarts power on. The NVM tearing save write functionality covers FPT_FLS.1 “Failure with preservation of secure state” since if the programming was not successful, the old data are still present and valid, which ensures a secure state although a programming failure occurred. This action includes also FDP_SDI.1 “Stored data integrity monitoring” as the new data to be programmed are checked for integrity and correct programming before the page with the old data becomes the new physical page for the next new data.

The covered security functional requirement is also FPT_PHP.3 “Resistance to physical attack”, since these measures make it difficult to manipulate the write process of the NVM.

The covered security functional requirements are FPT_FLS.1, FPT_PHP.3 and FDP_SDI.1.

The TOE is protected against fault and modifying attacks. The core provides the functionality of double-computing and result comparison of all tasks to detect incorrect calculations. The detection of an incorrect calculation is stored and the TOE enters a defined secure state which causes the chip internal reset process.

The implementation of two CPUs computing on the same data is by this one of the most important security features of this platform. As the results of both CPUs are compared at the end, a fault induction of modifying attacks would have to be done on both CPUs at the correct place with the correct timing – despite all other countermeasures like dynamic masking, encryption and others. As

the comparison and the register files are also protected by various measures successful manipulative attacks are seen as being not practical.

During start up, the STS performs various configurations and subsystem tests. After the STS has finished, the operating system or application can call the User Mode Security Life Control (UMSLC) test. The UMSLC checks the alarm lines and number of functions and sensors for correct operation.

This test can be released actively by the user software during normal chip operation at any time.

In the case that a physical manipulation or a physical probing attack is detected, the processing of the TOE is immediately stopped and the TOE enters a secure state called security reset.

The covered security functional requirements are FPT_FLS.1, FPT_PHP.3 and FPT_TST.2.

As physical effects or manipulative attacks may also address the program flow of the user software, a watchdog timer and a check point register are implemented. These features allow the user to check the correct processing time and the integrity of the program flow of the user software.

Another measure against modifying and perturbation respectively differential fault attacks (DFA) is the implementation of backward calculation in the SCP. By this induced errors are discovered.

The covered security functional requirements are FPT_FLS.1, FDP_IFC.1, FPT_ITT.1, FDP_ITT.1 and FPT_PHP.3.

The RMS provides the user also the testing of all security features enabled to generate an alarm. This security testing is called user mode security life control (UMSLC). As attempts to modify the security features will be detected from the test, the covered security functional requirement is FPT_TST.2.

All communication via the busses is in addition protected by a monitored hardware handshake. If the handshake was not successful an alarm is generated.

The covered security functional requirements are FPT_FLS.1 and FPT_PHP.3.

The virtual memory system and privilege level model are enforced by the MMU. This controls the access rights throughout the TOE. There is a clear differentiation within the privilege levels defined. The covered security functional requirements are FDP_ACC.1, FDP_ACF.1, FMT_MSA.1, FMT_MSA.3 and FMT_SMF1.

The **SF_PMA** "Protection against Modifying Attacks" covers the security functional requirements FPT_PHP.3, FDP_IFC.1, FPT_ITT.1, FDP_ITT.1, FMT_MSA.1, FMT_MSA.3, FMT_SMF.1, FDP_ACC.1, FDP_ACF.1, FRU_FLT.2, FPT_TST.2, FDP_SDI.1, FDP_SDI.2 and FPT_FLS.1.

8.4 SF_PLA: Protection against Logical Attacks

The memory access control of the TOE uses a memory management unit (MMU) to control the access to the available physical memory by using virtual memory addresses and to segregate the code and data to a privilege level model. The MMU controls the address permissions of the privileged levels and gives the software the possibility to define different access rights. The address permissions of the privilege levels are controlled by the MMU. In case of an access violation the MMU will trigger a reset and then a trap service routine can react on the access violation. The policy of setting up the MMU and specifying the memory ranges, to a certain extend, for the privilege levels – with the exception of the IFX level - is defined from the user software (OS).

As the TOE provides support for separation of memory areas the covered security functional requirements are FDP_ACC.1 "Subset access control", FDP_ACF.1 "Security attribute based access control", FMT_MSA.3 "Static attribute initialization", FMT_MSA.1 "Management of security attributes" and FMT_SMF.1 "Specification of Management functions".

The TOE provides the possibility to protect the property rights of user code and data by the encryption of the SOLID FLASH™ memory areas with a specific key defined by the user. Due to this key management FDP_ACF.1 is fulfilled. In addition, all memories present on the TOE are individually encrypted using individual keys assigned by complex key management. All data are protected by

means of encryption or masking also during transportation via the busses. Induced errors are recognized by the Integrity Guard concept and lead to an alarm. In case of security critical errors a security alarm is generated and the TOE ends up in a secure state. The covered security functional requirements are FPT_PHP.3, FDP_ITT.1, FDP_IFC.1 and FPT_FLS.1.

Beside the access protection and key management, also the use of illegal operation code is detected and will release a security reset.

The **SF_PLA** "Protection against Logical Attacks" covers the security functional requirements FDP_ACC.1, FDP_ACF.1, FMT_MSA.1, FMT_MSA.3, FPT_PHP.3, FDP_ITT.1, FDP_IFC.1, FPT_FLS.1 and FMT_SMF.1.

8.5 SF_CS: Cryptographic Support

The TOE is equipped with several hardware accelerators and software modules to support the standard symmetric and asymmetric cryptographic operations. This security function is introduced to include the cryptographic operation in the scope of the evaluation as the cryptographic function respectively mathematic algorithm itself is not used from the TOE security policy. On the other hand these functions are of special interest for the use of the hardware as platform for the software. The components are a co-processor supporting the DES and AES algorithms and a combination of a co-processor and software modules to support RSA cryptography, RSA key generation, ECDSA signature generation and verification, ECDH key agreement and EC public key calculation and public key testing.

8.5.1 3DES

The TOE supports the encryption and decryption in accordance with the specified cryptographic algorithm Triple Data Encryption Standard (3DES) and with cryptographic key sizes of 112 bit or 168 bits meeting the standard:

National Institute of Standards and Technology (NIST), Technology Administration, U.S. Department of Data Encryption Standard (DES), NIST Special Publication 800-67, Version 1.1

The TOE implements various block cipher modes of which the user can choose. More details are given in the confidential Security Target [16]. Please consider also the statement of chapter 7.1.4.1.

The covered security functional requirements are FCS_COP.1/DES.

8.5.2 AES

The TOE supports the encryption and decryption in accordance with the specified cryptographic algorithm Advanced Encryption Standard (AES) and cryptographic key sizes of 128 bit or 192 bit or 256 bit that meet the standard:

U.S. Department of Commerce, National Institute of Standards and Technology, Information Technology Laboratory (ITL), Advanced Encryption Standard (AES), FIPS PUB 197.

Please consider also the statement of chapter 7.1.4.1.

The covered security functional requirement is FCS_COP.1/AES.

8.5.3 RSA

Encryption, Decryption, Signature Generation and Verification

The TSF shall perform encryption and decryption in accordance with a specified cryptographic algorithm Rivest-Shamir-Adleman (RSA) and cryptographic key sizes 1024 - 4096 bits that meet the following standards

Encryption:

According to section 5.1.1 RSAEP in PKCS v2.1 RFC3447, without 5.1.1.1.

Decryption (with or without CRT):

According to section 5.1.2 RSADP in PKCS v2.1 RFC3447 for $u = 2$, i.e., without any (r_i, d_i, t_i) , $i > 2$, therefore without 5.1.2.2.b (ii)&(v), without 5.1.2.1. 5.1.2.2.a, only supported up to $n < 2^{2048}$

Signature Generation (with or without CRT)::

According to section 5.2.1 RSASP1 in PKCS v2.1 RFC3447 for $u = 2$, i.e., without any (r_i, d_i, t_i) , $i > 2$, therefore without 5.2.1.2.b (ii)&(v), without 5.2.1.1. 5.2.1.2.a, only supported up to $n < 2^{2048}$

Signature Verification:

According to section 5.2.2 RSAVP1 in PKCS v2.1 RFC3447, without 5.2.2.1.

Please consider also the statement of chapter 7.1.4.1.

Asymmetric Key Generation

The TSF shall generate cryptographic keys in accordance with a specified cryptographic key generation algorithm *RSA specified in PKCS#1 v2.1* and specified cryptographic key sizes of 1024 – 4096 bits that meet the following standard:

According to section 3.2(2) in PKCS v2.1 RFC3447, for $u=2$, i.e., without any (r_i, d_i, t_i) , $i > 2$. For $p \times q < 2^{2048}$ additionally according to section 3.2(1).

Note 18:

For easy integration of RSA functions into the user's operating system and/or application, the library contains single cryptographic functions respectively primitives which are compliant to the standard. The primitives are referenced above. Therefore, the library supports the user to develop an application representing the standard if required.

Please consider also the statement of chapter 7.1.4.1.

End of note.

The covered security functional requirement is FCS_COP.1/RSA and FCS_CKM.1/RSA.

8.5.4 Elliptic Curves EC

The certification covers the standard NIST [14] and Brainpool [15] Elliptic Curves with key lengths of 192 to 521 Bits, due to national AIS32 regulations by the BSI. Note that numerous other side channel attack resistant curve types exist, which the user optionally can add in the composition certification process.

Signature Generation and Verification

The TSF shall perform signature generation and signature verification in accordance with a specified cryptographic algorithm ECDSA and cryptographic key sizes 192 - 521 bits that meet the following standard:

Signature Generation:

1. According to section 7.3 in ANSI X9.62 - 2005
Not implemented is step d) and e) thereof.
The output of step e) has to be provided as input to our function by the caller.
Deviation of step c) and f):
The jumps to step a) were substituted by a return of the function with an error code, the jumps are emulated by another call to our function.
2. According to sections 6.2 (6.2.2. + 6.2.3) in ISO/IEC 15946-2:2002
Not implemented is section 6.2.1:
The output of 5.4.2 has to be provided by the caller as input to the function.

Signature Verification:

1. According to section 7.4.1 in ANSI X9.62-2005
Not implemented is step b) and c) thereof.
The output of step c) has to be provided as input to our function by the caller.
Deviation of step d):
Beside noted calculation, our algorithm adds a random multiple of BasepointerOrder n to the calculated values $u1$ and $u2$.
2. According to sections 6.4 (6.4.1. + 6.4.3 + 6.4.4) in ISO/IEC 15946-2:2002
Not implemented is section 6.4.2:
The output of 5.4.2 has to be provided by the caller as input to the function.

Asymmetric Key Generation

The TSF shall generate cryptographic keys in accordance with a specified cryptographic key generation algorithm Elliptic Curve EC specified in ANSI X9.62-1998 and ISO/IEC 15946-1:2002 and specified cryptographic key sizes 192 - 521 bits that meet the following standard:

ECDSA Key Generation:

1. According to the appendix A4.3 in ANSI X9.62-2005
the cofactor h is not supported.
2. According to section 6.1 (not 6.1.1) in ISO/IEC 15946-1:2002

Asymmetric Key Agreement

The TSF shall perform elliptic curve Diffie-Hellman key agreement in accordance with a specified cryptographic algorithm ECDH and cryptographic key sizes 192 - 521 bits that meet the following standard:

1. According to section 5.4.1 in ANSI X9.63-2001
Unlike section 5.4.1.3 our, implementation not only returns the x-coordinate of the shared secret, but rather the x-coordinate and y-coordinate.
2. According to sections 8.4.2.1, 8.4.2.2, 8.4.2.3, and 8.4.2.4 in ISO/IEC 15946-3:2002:
The function enables the operations described in the four sections.

Note 19:

For easy integration of EC functions into the user's operating system and/or application, the library contains single cryptographic functions respectively primitives which are compliant to the standard. The primitives are referenced above. Therefore, the library supports the user to develop an application representing the standard if required.

End of note.

The covered security functional requirements are FCS_COP.1/ECDSA, FCS_CKM.1/EC and FCS_COP.1/ECDH.

8.5.5 SHA-2

The TOE comes optionally with the SHA-2 library for hash value calculation. Regarding the SHA-2 library it has to be noted that the secure hash-algorithm SHA-2 is intended to be used for signature generation, verification and generic data integrity checks. The use for keyed hash operations like HMAC or similar security critical operations involving keys, is not subject of this TOE and requires specific security improvements and DPA analysis including the operating system, which is not part of this TOE. Nevertheless, following is valid:

The TSF shall perform hash-value calculation of user chosen data in accordance with a specified cryptographic algorithm SHA-2 and with cryptographic key sizes of none that meet the following standards:

U.S. Department of Commerce / National Bureau of Standards, Secure Hash Algorithm, FIPS PUB 180-3, 2008-October, section 6.2 SHA-256 and section 6.4 SHA-512.

The covered security functional requirement is FCS_COP.1/SHA.

8.5.6 Toolbox Library

The toolbox provides the following basic long integer arithmetic and modular functions in software, supported by the cryptographic coprocessor: Addition, subtraction, division, multiplication, comparison, reduction, modular addition, modular subtraction, modular multiplication, modular inversion and modular exponentiation. No security relevant policy, mechanism or function is supported. The toolbox library is deemed for software developers as support for simplified implementation of long integer and modular arithmetic operations.

The toolbox does not cover security functional requirements.

8.5.7 Base Library

The Base Library provides the low level interface to the asymmetric cryptographic coprocessor and has no user available interface. The base library does not provide any security functionality, implements no security mechanism, and does not provide additional specific security functionality.

The Base Library does not cover security functional requirements and has no user interface.

8.5.8 TRNG

Random data is essential for cryptography as well as for security mechanisms. The TOE is equipped with a physical True Random Number Generator (TRNG, FCS_RNG.1). The random data can be used from the Smartcard Embedded Software and is also used from the security features of the TOE, like masking. The TRNG implements also self testing features. The TRNG fulfils the requirements from the functionality class P2 of the AIS31 [6].

The covered security functional requirement is FCS_RNG.1, FPT_PHP.3, FDP_ITT.1, FPT_ITT.1, FPT_TST.2 and FPT_FLS.1.

The **SF_CS** "Cryptographic Support" covers the security functional requirements FCS_COP.1/DES, FCS_COP.1/AES, FCS_COP.1/RSA, FCS_CKM.1/RSA, FCS_COP.1/ECDSA, FCS_CKM.1/EC, FCS_COP.1/ECDH, FCS_COP.1/SHA, FPT_PHP.3, FDP_ITT.1, FPT_ITT.1, FPT_TST.2, FPT_FLS.1 and FCS_RNG.1.

Note 20:

The cryptographic libraries RSA, EC, SHA-2 and the Toolbox library are delivery options. If one of the libraries RSA, EC and Toolbox or combination hereof are delivered, the Base Lib is automatically part of it. Therefore the TOE may come with free combinations of or even without these libraries. In the case of coming without one or any combination of the cryptographic libraries RSA, EC and SHA-2, the TOE does not provide the Additional Specific Security Functionality Rivest-Shamir-Adleman Cryptography (RSA) and/or Elliptic Curve Cryptography (EC) and/or SHA-2. The Toolbox and Base Library are no cryptographic libraries and provide no additional specific security functionality.
End of note.

Note 21:

This TOE can come with both crypto co-processors accessible, or with a blocked SCP or with a blocked Crypto2304T, or with both crypto co-processors blocked. The blocking depends on the customer demands prior to the production of the hardware. In case the SCP is blocked, no AES and 3DES computation supported by hardware is possible. In case the Crypto2304T is blocked, no RSA and EC computation supported by hardware is possible. The use of the SHA-2 library is also possible with both crypto coprocessors blocked. No accessibility of the deselected cryptographic co-processors is without impact on any other security policy of the TOE; it is exactly equivalent to the situation where the user decides just not to use the cryptographic co-processors.
End of note.

8.6 Assignment of Security Functional Requirements to TOE's Security Functionality

The justification and overview of the mapping between security functional requirements (SFR) and the TOE's security functionality (SF) is given in sections the sections above. The results are shown in Table 19. The security functional requirements are addressed by at least one relating security feature.

The various functional requirements are often covered manifold. As described above the requirements ensure that the TOE is checked for correct operating conditions and if a not correctable failure occurs that a stored secure state is achieved, accompanied by data integrity monitoring and actions to maintain the integrity although failures occurred. An overview is given in following table:

Table 19: Mapping of SFR and SF

Security Functional Requirement	SF_DPM	SF_PS	SF_PMA	SF_PLA	SF_CS
FAU_SAS.1	X				
FMT_LIM.1	X				
FMT_LIM.2	X				
FDP_ACC.1	X		X	X	
FDP_ACF.1	X		X	X	
FPT_PHP.3	X	X	X	X	X
FDP_ITT.1	X	X	X	X	X
FDP_SDI.1			X		
FDP_SDI.2			X		
FDP_IFC.1		X	X	X	
FMT_MSA.1	X		X	X	
FMT_MSA.3	X		X	X	
FMT_SMF.1	X		X	X	
FRU_FLT.2			X		
FPT_ITT.1	X	X	X		X
FPT_TST.2			X		X
FPT_FLS.1		X	X	X	X
FCS_RNG.1					X
FCS_COP.1/DES					X
FCS_COP.1/AES					X
FCS_COP.1/RSA					X

Security Functional Requirement	SF_DPM	SF_PS	SF_PMA	SF_PLA	SF_CS
FCS_COP.1/ECDSA					X
FCS_COP.1/ECDH					X
FCS_COP.1/SHA					X
FCS_CKM.1/RSA					X
FCS_CKM.1/EC					X

8.7 Security Requirements are internally Consistent

For this chapter the PP [1] section 6.3.4 can be applied completely.

In addition to the discussion in section 6.3 of PP [1] the security functional requirement FCS_COP.1 is introduced. The security functional requirements required to meet the security objectives O.Leak-Inherent, O.Phys-Probing, O.Malfunction, O.Phys-Manipulation and O.Leak-Forced also protect the cryptographic algorithms implemented according to the security functional requirement FCS_COP.1. Therefore, these security functional requirements support the secure implementation and operation of FCS_COP.1.

As disturbing, manipulating during or forcing the results of the test checking the security functions after TOE delivery, this security functional requirement FPT_TST.2 has to be protected. An attacker could aim to switch off or disturb certain sensors or filters and preserve the detection of his manipulation by blocking the correct operation of FPT_TST.2. The security functional requirements required to meet the security objectives O.Leak-Inherent, O.Phys-Probing, O.Malfunction, O.Phys-Manipulation and O.Leak-Forced also protect the security functional requirement FPT_TST.2. Therefore, the related security functional requirements support the secure implementation and operation of FPT_TST.2.

The requirement FPT_TST.2 allows testing of some security mechanisms by the Smartcard Embedded Software after delivery. In addition, the TOE provides an automated continuous user transparent testing of certain functions.

The implemented privilege level concept represents the area based memory access protection enforced by the MMU. As an attacker could attempt to manipulate the privilege level definition as defined and present in the TOE, the functional requirement FDP_ACC.1 and the related other requirements have to be protected themselves. The security functional requirements required to meet the security objectives O.Leak-Inherent, O.Phys-Probing, O.Malfunction, O.Phys-Manipulation and O.Leak-Forced also protect the area based memory access control function implemented according to the security functional requirement described in the security functional requirement FDP_ACC.1 with reference to the Memory Access Control Policy and details given in FDP_ACF.1. Therefore, those security functional requirements support the secure implementation and operation of FDP_ACF.1 with its dependent security functional requirements.

The requirement FDP_SDI.2.1 allows detection of integrity errors of data stored in memory. FDP_SDI.2.2 in addition allows correction of one bit errors or taking further action. Both meet the security objective O.Malfunction. The requirements FRU_FLT.2, FPT_FLS.1, and FDP_ACC.1 which also meet this objective are independent from FDP_SDI.2 since they deal with the observation of the correct operation of the TOE and not with the memory content directly.

9 References

9.1 Literature

- [1] Security IC Platform Protection Profile, Version 1.0, 15.06.2007, BSI-PP-0035
- [2] Common Criteria for Information Technology Security Evaluation Part 1: Introduction and General Model; Version 3.1 Revision 3 July 2009, CCMB-2009-07-001
- [3] Common Criteria for Information Technology Security Evaluation Part 2: Security Functional Requirements; Version 3.1 Revision 3 July 2009, CCMB-2009-07-002
- [4] Common Criteria for Information Technology Security Evaluation Part 3: Security Assurance Requirements; Version 3.1 Revision 3 July 2009, CCMB-2009-07-003
- [5] Status report, List of all available user guidance
- [6] Functionality classes and evaluation methodology for physical random number generators taken from AIS31, Version 1, 25.09.2001
- [7] M7892 Family Hardware Reference Manual as versioned in Table 1: Identification
- [11] Joint Interpretation Library, Application of Attack Potential to Smartcards, Version 2.7, February 2009
- [13] SLE 70 Family Programmer's Reference User Manual, as versioned in Table 1: Identification
- [14] NIST: FIPS publication 186-3: Digital Signature Standard (DSS), June 2009
- [15] IETF: RFC 5639, Elliptic Curve Cryptography (ECC) Brainpool Standard Curves and Curve Generation, March 2010, <http://www.ietf.org/rfc/rfc5639.txt>
- [16] Confidential Security Target as versioned in Table 1: Identification

Note that the versions of these documents will be defined at the end of the evaluation and listed in the certification report.

10 Appendix

In Table 21 the hash signatures of the respective CL70 Crypto Library file are documented. For convenience purpose several hash values are referenced.

Table 20: Reference hash values of the CL70 Crypto Libraries

RSA, EC, Toolbox Version v1.02.013:

CI70-LIB-base-XSMALL-HUGE.lib:

MD5=d080392bc14a65de9094d846498f28a3

SHA1=4149318953b22876c6d9f712e084f00dccaac88f

SHA256=c08bf0778baf3a25123e1ff45590eeec6bff29cb38ede2a07a377f968d5eeade

CI70-LIB-2k-XSMALL-HUGE.lib:

MD5=e1829fa50cbd46f912e40528e92e77d4

SHA1=41a4c013fe08cbcf4917753076d8c035657040a0

SHA256=afe2dc4b3eceb6d67dab8add2581f3ceb4f6268d5f6c0091f7d975afbbec86ca

CI70-LIB-4k-XSMALL-HUGE.lib:

MD5=3c2ac3030c2abbc9e6d32b46c244f59b

SHA1=0867b74168c2b228a12c2835de92262d9536bdde

SHA256=11736a910bdc9e8a2d74b56db60d2002ff8bd9ba49be8c8fc08d744128ac6e3b

CI70-LIB-ecc-XSMALL-HUGE.lib:

MD5=9ccf23232e16645448323670e8fa3171

SHA1=315952fc79e4e711e6f95e2b9d547a5c91d88d1c

SHA256=69ad0d5bfaf2308c24d19ee8824d61952a73c273dd57ee19612dace6ba92e772

CI70-LIB-toolbox-XSMALL-HUGE.lib:

MD5=4c577bcf9853c8c030b84ebe19d22b8d

SHA1=4c12dc67dad4bbe88c4b23c43a275b3ad3be71f3

SHA256=e6de94b27ffce43b8a023c04ceb86795585617b4cac8e7a53a78cf273b1fe8fc



SHA-2 Library Version v1.01:

SHA-2 values computed from: SLE70-SHA2-Lib_RE_1v01_2009-06-29.LIB

MD5=70d2df490185b419fb820d597d82d117

SHA1= df15ff79b5f5ab70bbad0ee031953e1877cabd47

SHA256=765fc5d47cf8274833476406b24010a56ebcfd4b0972704ddd27e2d3e3e086f8

11 List of Abbreviations

AES	Advanced Encryption Standard
AIS31	“Anwendungshinweise und Interpretationen zu ITSEC und CC Funktionalitätsklassen und Evaluationsmethodologie für physikalische Zufallszahlengeneratoren”
APB	Advanced Peripheral Bus
API	Application Programming Interface
AXI	Advanced eXtensible Interface Bus Protocol
BPU	Bill Per Use
CC	Common Criteria
CI	Chip Identification Mode (STS-CI)
CIM	Chip Identification Mode (STS-CI), same as CI
CPU	Central Processing Unit
CRC	Cyclic Redundancy Check
Crypto2304T	Asymmetric Cryptographic Processor
CRT	Chinese Remainder Theorem
DES	Data Encryption Standard
DPA	Differential Power Analysis
DFA	Differential Failure Analysis
EC	Elliptic Curve Cryptography
ECC	Error Correction Code
EDC	Error Detection Code
EDU	Error Detection Unit
EMA	Electro magnetic analysis
FL	Flash Loader
Flash	SOLID FLASH™ Flash Memory
HW	Hardware
IC	Integrated Circuit
ICO	Internal Clock Oscillator
ID	Identification
IMM	Interface Management Module
ITP	Interrupt and Peripheral Event Channel Controller
I/O	Input/Output
IRAM	Internal Random Access Memory
ITSEC	Information Technology Security Evaluation Criteria
M	Mechanism

MED	Memory Encryption and Decryption
MMU	Memory Management Unit
O	Object
OS	Operating system
PEC	Peripheral Event Channel
PRNG	Pseudo Random Number Generator
PROM	Programmable Read Only Memory
RAM	Random Access Memory
RFI	Radio Frequency Interface
RMS	Resource Management System
RNG	Random Number Generator
ROM	Read Only Memory
RSA	Rives-Shamir-Adleman Algorithm
SAM	Service Algorithm Minimal
SCP	Symmetric Cryptographic Processor
SF	Security Feature
SFR	Special Function Register, as well as Security Functional Requirement The specific meaning is given in the context
SOLID FLASH™	Stands for the Electrically Erasable and Programmable Read Only Memory
SPA	Simple power analysis
STS	Self Test Software
SW	Software
SO	Security objective
T	Threat
TM	Test Mode (STS)
TOE	Target of Evaluation
TRNG	True Random Number Generator
TSC	TOE Security Functions Control
TSF	TOE Security Functionality
UART	Universal Asynchronous Receiver/Transmitter
UM	User Mode (STS)
UmSLC	User mode Security Life Control
WDT	Watch Dog Timer
XRAM	eXtended Random Access Memory
3DES	Triple DES Encryption Standard

12 Glossary

Application Program/Data	Software which implements the actual TOE functionality provided for the user or the data required for that purpose
Bill-Per-Use	Bill-Per-Use concept allowing the user to configure the chips
Central Processing Unit	Logic circuitry for digital information processing
Chip	Integrated Circuit
Chip Identification Data	Data stored in the SOLID FLASH™ containing the chip type, lot number (including the production site), die position on wafer and production week and data stored in the ROM containing the STS version number
Chip Identification Mode	Operational status phase of the TOE, in which actions for identifying the individual chip by transmitting the Chip Identification Data take place
Controller	Integrated Circuit with integrated memory, CPU and peripheral devices
Crypto2304T	Cryptographic coprocessor for asymmetric cryptographic operations (RSA, Elliptic Curves)
Cyclic Redundancy Check	Process for calculating checksums for error detection
End User	Person in contact with a TOE who makes use of its operational capability
Firmware	Is software essential to put the chip into operation. The firmware is located in the ROM and parts of it in the SOLID FLASH™
Flash Loader	Software enabling to download software after delivery
Hardware	Physically present part of a functional system (item)
Integrated Circuit	Component comprising several electronic circuits implemented in a highly miniaturized device using semiconductor technology
Mechanism	Logic or algorithm which implements a specific security function in hardware or software
Memory Encryption and Decryption	Module and method of encoding/decoding data transfer between CPU and memory
Memory	Hardware part containing digital information (binary data)
Microprocessor	CPU with peripherals
Object	Physical or non-physical part of a system which contains information and is acted upon by subjects
Operating System	Software which implements the basic TOE actions necessary to run the user application

Programmable Read Only Memory	Non-volatile memory which can be written once and then only permits read operations
Random Access Memory	Volatile memory which permits write and read operations
Random Number Generator	Hardware part for generating random numbers
Read Only Memory	Non-volatile memory which permits read operations only
Resource Management System	Part of the firmware containing SOLID FLASH™ programming routines, AIS31 testbench etc.
SCP	Is the symmetric cryptographic coprocessor for symmetric cryptographic operations (3DES, AES).
Self Test Software	Part of the firmware with routines for controlling the operating state and testing the TOE hardware
Security Function	Part(s) of the TOE used to implement part(s) of the security objectives
Security Target	Description of the intended state for countering threats
Smart Card	Is a plastic card in credit card format with built-in chip. Other form factors are also possible, i.e. if integrated into mobile devices
Software	Information (non-physical part of the system) which is required to implement functionality in conjunction with the hardware (program code)
SOLID FLASH™	Electrically Erasable and Programmable Read Only Memory, a non-volatile memory permitting electrical read and write operations
Subject	Entity, generally in the form of a person, who performs actions
Target of Evaluation	Product or system which is being subjected to an evaluation
Test Mode	Operational status phase of the TOE in which actions to test the TOE hardware take place
Threat	Action or event that might prejudice security
User Mode	Operational status phase of the TOE in which actions intended for the user takes place

Infineon Technologies – innovative semiconductor solutions for energy efficiency, mobility and security.

